

I600



User guide

Barco NV
Beneluxpark 21, 8500 Kortrijk, Belgium
www.barco.com

Manufacturer: Barco (Wuxi) Technology Co., Ltd.
No. 38, Chunhui Middle Road, XiShan District, 214101 Wuxi CHINA
合法制造商: 巴可(无锡)科技有限公司
中国无锡市锡山区春晖中路38号, 邮编214101

Copyright ©

All rights reserved. No part of this document may be copied, reproduced or translated. It shall not otherwise be recorded, transmitted or stored in a retrieval system without the prior written consent of Barco.

Changes

Barco provides this manual 'as is' without warranty of any kind, either expressed or implied, including but not limited to the implied warranties or merchantability and fitness for a particular purpose. Barco may make improvements and/or changes to the product(s) and/or the program(s) described in this publication at any time without notice.

This publication could contain technical inaccuracies or typographical errors. Changes are periodically made to the information in this publication; these changes are incorporated in new editions of this publication.

The latest edition of Barco manuals can be downloaded from the Barco website <https://www.barco.com>.

Trademarks

Brand and product names mentioned in this manual may be trademarks, registered trademarks or copyrights of their respective holders. All brand and product names mentioned in this manual serve as comments or examples and are not to be understood as advertising for the products or their manufacturers.

Guarantee and Compensation

Barco provides a guarantee relating to perfect manufacturing as part of the legally stipulated terms of guarantee. On receipt, the purchaser must immediately inspect all delivered goods for damage incurred during transport, as well as for material and manufacturing faults Barco must be informed immediately in writing of any complaints.

The period of guarantee begins on the date of transfer of risks, in the case of special systems and software on the date of commissioning, at latest 30 days after the transfer of risks. In the event of justified notice of complaint, Barco can repair the fault or provide a replacement at its own discretion within an appropriate period. If this measure proves to be impossible or unsuccessful, the purchaser can demand a reduction in the purchase price or cancellation of the contract. All other claims, in particular those relating to compensation for direct or indirect damage, and also damage attributed to the operation of software as well as to other services provided by Barco, being a component of the system or independent service, will be deemed invalid provided the damage is not proven to be attributed to the absence of properties guaranteed in writing or due to the intent or gross negligence or part of Barco.

If the purchaser or a third party carries out modifications or repairs on goods delivered by Barco, or if the goods are handled incorrectly, in particular if the systems are operated incorrectly or if, after the transfer of risks, the goods are subject to influences not agreed upon in the contract, all guarantee claims of the purchaser will be rendered invalid. Not included in the guarantee coverage are system failures which are attributed to programs or special electronic circuitry provided by the purchaser, e.g. interfaces. Normal wear as well as normal maintenance are not subject to the guarantee provided by Barco either.

The environmental conditions as well as the servicing and maintenance regulations specified in this manual must be complied with by the customer.

Patent protection

Please refer to <https://www.barco.com/about-barco/legal/patents>.

Table of contents

1	Safety	9
1.1	General considerations	10
1.2	Important safety instructions	11
1.3	Product safety labels	15
1.4	High Brightness precautions: Hazard Distance	16
1.5	HD for fully enclosed projection systems	18
1.6	HD in function of modifying optics	20
1.7	HD calculation of multi-projector stacks	20
1.8	Compliance	21
1.9	Download Product Manual	21
2	I600 introduction	23
2.1	Projector orientation	24
2.2	Projector components	24
2.3	Projector airflow	24
2.4	Projector status	25
2.5	Pulse Prospector	26
3	Local keypad	27
3.1	Local keypad functions	28
3.2	Local keypad backlight	28
3.3	LCD touch panel	29
4	Basic Remote Control Unit	31
4.1	Basic remote functions	32
4.2	Basic remote batteries	32
5	Pulse Remote Control Unit	35
5.1	Pulse RCU functions	36
5.2	Pulse RCU battery installation	36
5.3	Pulse RCU on/off button	37
5.4	Pulse RCU “button pressed indicator”	38
5.5	Pulse RCU “RGB filter” button	38
5.6	Pulse RCU “Projector OSD on/off” button	39
5.7	Using the XLR connector of the RCU	39
5.8	Using the mini-jack connector of the RCU	39
5.9	Pulse RCU silicone protection sleeve (optional)	40

6	Powering on / off	43
6.1	Power modes	44
6.2	Power On the projector.....	44
6.3	Power Off the projector.....	45
6.4	Power mode transitions.....	46
7	Inputs & Communication	49
7.1	Control & Communication module	50
7.2	Pulse HDBaseT input module.....	51
7.3	Pulse Quad Combo input Mk III.....	51
7.4	Pulse Quad DP 1.2 input.....	53
7.5	Pulse SFP input.....	53
8	Dust filter	55
8.1	Replacing the dust filter.....	56
8.2	Vacuum cleaning of the dust filter foam.....	56
8.3	Washing and drying the dust filter foam.....	57
9	Projector maintenance	59
9.1	One month maintenance actions.....	60
9.2	Software update.....	60
9.3	Cleaning the lens.....	62
9.4	Cleaning the exterior of the projector.....	62
A	Specifications	63
A.1	I600-4K8 specifications.....	64
A.2	I600-4K10 specifications.....	65
A.3	I600-4K15 specifications.....	67
A.4	Specifications SDI inputs.....	69
A.5	Specifications HDMI inputs.....	70
A.6	Specifications HDBaseT input.....	71
A.7	Specifications DisplayPort 1.4 inputs.....	71
A.8	Specifications DisplayPort 1.2 inputs.....	72
A.9	Specifications SFP inputs.....	73
B	DMX chart	75
B.1	DMX chart input module position.....	76
B.2	DMX chart, Basic.....	76
B.3	DMX chart, Extended.....	77
C	Dimensions	81
C.1	Projector outer dimensions.....	82
C.2	Mounting holes bottom plate.....	83
D	Regulatory	85
D.1	Contact information.....	86
D.2	Production information.....	86
D.3	Product compliance EU.....	86
D.4	Product compliance UK.....	87
D.5	Product compliance US.....	87
D.6	Product compliance Turkey.....	87
D.7	Product compliance EAC.....	88
D.8	Product compliance China.....	88
D.9	Product compliance Taiwan.....	89
D.10	Trademark notice.....	91

D.11 Product privacy statement	91
Glossary	93
Index	95

Safety

1

1.1	General considerations	10
1.2	Important safety instructions	11
1.3	Product safety labels.....	15
1.4	High Brightness precautions: Hazard Distance.....	16
1.5	HD for fully enclosed projection systems.....	18
1.6	HD in function of modifying optics	20
1.7	HD calculation of multi-projector stacks	20
1.8	Compliance.....	21
1.9	Download Product Manual	21

About this document

Read this document attentively. It contains important information to prevent personal injury while installing and using the I600 product. Furthermore, it includes several cautions to prevent damage to the unit. Ensure that all safety guidelines, safety instructions and warnings mentioned in this chapter are understood and followed before installing the I600 product.

Clarification of the term “I600” used in this document

When referring in this document to the term “I600” means that the content is applicable for following Barco products:

- I600-4K8, I600-4K10, I600-4K15

Model certification name

- I600-4K8 : GPI-A
- I600-4K10 : GPI-B
- I600-4K15 : GPI-C



Barco provides a guarantee relating to perfect manufacturing as part of the legally stipulated terms of guarantee. Observing the specification mentioned in this chapter is critical for optimal performance. Neglecting this can result in loss of warranty.

1.1 General considerations



WARNING: Be aware of suspended loads.



WARNING: When suspending loads, wear a hard hat to reduce the risk of personal injury.



WARNING: Be careful while working with heavy loads.



WARNING: Mind your fingers while working with heavy loads.



WARNING: In case of emergency, disconnect the device from the mains power supply. In case the power input at the projector side is not accessible, a readily accessible general disconnect device shall be incorporated.

General safety instructions

- Before operating this equipment please read this manual thoroughly and retain it for future reference.
- All warnings on the unit and in its documentation manuals must be adhered to.
- Installation and preliminary adjustments must be performed by qualified Barco personnel or by authorized Barco service dealers.
- This product contains no user serviceable parts. Attempts to modify/replace mechanics or electronics inside the housing or compartments will violate any warranties and may be hazardous.
- All instructions for operating and use of this equipment must be followed precisely.
- All local installation codes must be adhered to.

전원코드 사양

한국용: KC 인증품을 구매하여 사용하세요 - 플러그: 250 V~, 16 A; 전원 코드: 60227 IEC 53, 3G01.5 mm²; 커넥터: 250 V~, 16 A.

Notice on safety

This equipment is built in accordance with the requirements of the applicable international safety standards. These safety standards impose important requirements on the use of safety critical components, materials and insulation, in order to protect the user or operator against risk of electric shock and energy hazard and having access to live parts. Safety standards also impose limits to the internal and external temperature rises, radiation levels, mechanical stability and strength, enclosure construction and protection against the risk of fire. Simulated single fault condition testing ensures the safety of the equipment to the user even when the equipment's normal operation fails.

Notice on optical radiation

This projector embeds a light source incorporating high brightness lasers. The laser light is processed through the projector's optical path. Native laser light is not accessible by the end user in any use case. The light exiting the projection lens has been diffused within the optical path, representing a larger source and lower brightness than native laser light. Nevertheless the projected light can represent a significant risk for the human eye and skin when exposed directly within the beam. This risk is not specifically related to the characteristics of laser light but solely to the high thermal induced energy of the light source, which is equivalent with lamp based systems. Thermal eye injury is possible when exposed within the Hazard Distance (HD). The HD is defined from the projection lens surface towards the position of the projected beam where the intensity equals the applicable exposure limit as described in the chapter "Hazard Distance".

This projector is classified as a laser product under IEC 60825-1: 2014, EN 60825-1:2014+A11:2021. The projector, in particular the projection beam, is classified as a Risk Group (RG) under IEC EN 62471-5:2015.



WARNING: This projector has a built-in Class 4 laser module. Never attempt to disassemble or modify the laser module. Service only allowed by qualified service personnel.



WARNING: No direct exposure to the projection beam within the hazard distance shall be permitted for RG3 (Risk Group 3) IEC EN 62471-5:2015. Do not stare into the beam for RG2 (Risk Group 2) IEC EN 62471-5:2015.



CAUTION: Use of controls or adjustments or performance of procedures other than those specified herein may result in hazardous radiation exposure.

Optical radiation safety precautions

This projector is classified as CLASS 1 LASER PRODUCT - RISK GROUP 3.

Users definition

These projectors are intended “FOR PROFESSIONAL USE ONLY”, this means installation can only be carried out by trained and authorized persons.

Throughout this manual, the terms SERVICE PERSONNEL, INSTALLER refers to persons having appropriate technical training and experience necessary to be knowledgeable of potential hazards to which they are exposed (including, but not limited to HIGH VOLTAGE ELECTRIC and ELECTRONIC CIRCUITRY, HIGH TEMPERATURES and HIGH BRIGHTNESS SOURCES) in performing a task, and of measures to minimize the potential risks to themselves or other persons.

The term USER or OPERATOR of RG2 projectors refers to any other person than SERVICE PERSONNEL or INSTALLER. The term USER or OPERATOR of RG3 projectors refers to any person trained and authorized to operate professional RG3 projectors. The USER or OPERATOR may only perform the maintenance tasks set forth in the user manual or the maintenance tasks for which they are trained and authorized. All other maintenance tasks and service tasks must be performed by qualified SERVICE PERSONNEL.

1.2 Important safety instructions

To prevent the risk of electrical shock

- This product should be operated from a mono phase AC power source. Ensure that the mains voltage and capacity match the projectors electrical ratings. If you are unable to install the AC requirements, contact your electrician. Do not defeat the purpose of grounding.
- Use only the power cord supplied with your device. When no power cord for your region/country is provided, contact your dealer. The power cord must be suited for the electrical ratings indicated on the product ID label. Only power cords according to the local electrical code regulations can be used.
- This apparatus must be grounded (earthed) via the power cord.
- Do not allow anything to rest on the power cord. Do not locate this product where persons will walk on the cord. To disconnect the cord, pull it out by the plug. Never pull the cord itself.
- Do not operate the projector with a damaged cord. Replace the cord.
- Do not operate the projector if the projector has been dropped or damaged - until it has been examined and approved for operation by a qualified service technician.
- Position the cord so that it will not be tripped over, pulled, or contact hot surfaces.
- If an extension cord is necessary, a cord with a current rating at least equal to that of the projector should be used. A cord rated for less amperage than the projector may overheat.
- Do not expose this projector to rain or moisture.
- Do not immerse or expose this projector in water or other liquids.
- Do not spill liquid of any kind on this projector.
- Should any liquid or solid object fall into the cabinet, unplug the set and have it checked by qualified service personnel before resuming operations.
- Do not disassemble this projector, always take it to an authorized trained service person when service or repair work is required.
- Do not use an accessory attachment which is not recommended by the manufacturer.

- Lightning - For added protection for this video product during a lightning storm, or when it is left unattended and unused for long periods of time, unplug it from the wall outlet. This will prevent damage to the device due to lightning and AC power-line surges.
- Never push objects of any kind into this product through cabinet slots as they may touch dangerous voltage points or short out parts that could result in a risk of fire or electrical shock.
- If you are unable to insert the plug into the outlet, contact your electrician to replace your obsolete outlet. Do not defeat the purpose of the grounding-type plug.
- Ensure that the main power cord complies with the national regulations at the site where the equipment is used.
- Do not use unauthorized replacements.
- Make sure that no objects enter into the vents and openings of the set.
- The projector is designed for indoor use only. Never operate the unit outdoors.

To prevent personal injury

- To prevent injury and physical damage, always read this manual and all labels on the system before powering the projector or adjusting the projector.
- To prevent injury, take note of the weight of the projector. The projector weighs about 23.7 kg (52.3 lbs) without lens and rigging frame.
- To prevent injury, ensure that the lens and all covers are correctly installed. See installation procedures.
- Warning: high intensity light beam. NEVER look into the lens ! High luminance could result in damage to the eye.
- **Warning: extremely high brightness projector:** This projector embeds extremely high brightness (radiance) lasers; this laser light is processed through the projectors optical path. Native laser light is not accessible by the end user in any use case. The light exiting the projection lens has been diffused within the optical path, representing a larger source and lower radiance value than native laser light. Nevertheless the projected light represents a significant risk for the human eye when exposed directly within the beam. This risk is not specific related to the characteristics of laser light but solely to the high thermal induced energy of the light source; which is comparable with lamp based systems. Thermal retinal eye injury is possible when exposed within the Hazard Distance. The Hazard Distance (HD) is defined from the projection lens surface towards the position of the projected beam where the irradiance equals the maximum permissible exposure as described in the chapter "[High Brightness precautions: Hazard Distance](#)", page 16.
- Based on international requirements, no person is allowed to enter the projected beam within the zone between the projection lens and the related Hazard Distance (HD). This shall be physically impossible by creating sufficient separation height or by placing optional barriers. Within the restricted area operator training is considered sufficient. The applicable separation heights are discussed in "[High Brightness precautions: Hazard Distance](#)", page 16.
- Don't put your hand in front of the beam.
- This product contains no user serviceable parts. Attempts to modify/replace mechanics or electronics inside the housing or compartments will violate any warranties and may be hazardous.
- A special device ("rigged frame") based on an external frame must be used when the projector is deployed in a hanging configuration, or when several projector must be stacked. See installation manuals for the correct use of these devices.
- Never stack more than 2 projectors in a hanging configuration (truss) and never stack more than 3 projectors in a base stand configuration (table mount).
- When using the projector in a hanging configuration, always mount 2 safety cables. See installation manual for the correct use of these cables.
- Do not place this equipment on an unstable cart, stand, or table. The product may fall, causing serious damage to it and possible injury to the user.
- It is hazardous to operate without lens or shield. Lenses, shields or ultra violet screens shall be changed if they have become visibly damaged to such an extent that their effectiveness is impaired. For example by cracks or deep scratches.
- Never point or allow light to be directed on people or reflective objects within the HD zone.
- All operators shall have received adequate training and be aware of the potential hazards.
- In case of using an external cooling system position the hoses of the cooling system so that they will not be tripped over, pulled, or contact hot surfaces.

To prevent fire hazard

- Do not place flammable or combustible materials near the projector!

- Barco projection products are designed and manufactured to meet the most stringent safety regulations. This projector radiates heat on its external surfaces and from ventilation ducts during normal operation, which is both normal and safe. Exposing flammable or combustible materials into close proximity of this projector could result in the spontaneous ignition of that material, resulting in a fire. For this reason, it is absolutely necessary to leave an “exclusion zone” around all external surfaces of the projector whereby no flammable or combustible materials are present. The exclusion zone in the exhaust area must be not less than 100 cm (40”). The exclusion zone on the intake area must be not less than 50 cm (20”).
- Do not place any object in the projection light path at close distance to the projection lens output. The concentrated light at the projection lens output may result in damage, fire or burn injuries.
- Do not cover the projector or the lens with any material while the projector is in operation. Keep flammable and combustible materials away from the projector at all times. Mount the projector in a well ventilated area away from sources of ignition and out of direct sun light. Never expose the projector to rain or moisture. In the event of fire, use sand, CO₂ or dry powder fire extinguishers. Never use water on an electrical fire. Always have service performed on this projector by qualified service personnel. Always insist on genuine Barco replacement parts. Never use non-Barco replacement parts as they may degrade the safety of this projector.
- Ensure no misalignment can occur. Prolonged exposure of wooden walls at close distance (< 20 cm) can represent a fire risk. After alignment the projector shall be securely mounted to the pedestal.
- Slots and openings in this equipment are provided for ventilation. To ensure reliable operation of the projector and to protect it from overheating, these openings must not be blocked or covered. The openings should never be blocked by placing the projector too close to walls, or other similar surface. This projector should never be placed near or over a radiator or heat register. This projector should not be placed in a built-in installation or enclosure unless proper ventilation is provided.
- Projection rooms must be well ventilated or cooled in order to avoid build up of heat. It is necessary to vent hot exhaust air from projector and cooling system to the outside of the building.
- Let the projector cool completely before storing. Remove cord from the projector when storing.

To prevent battery explosion

- Danger of explosion if battery is incorrectly installed.
- Replace only with the same or equivalent type recommended by the manufacturer.
- For disposal of used batteries, always consult federal, state, local and provincial hazardous waste disposal rules and regulations to ensure proper disposal.

To prevent projector damage

Electrical

- This apparatus must be grounded (earthed) via the supplied 3 conductor AC power cable.
- Unplug this product from the wall outlet before cleaning. Do not use liquid cleaners or aerosol cleaners. Use a damp cloth for cleaning. Never use strong solvents, such as thinner or benzene, or abrasive cleaners, since these will damage the cabinet. Stubborn stains may be removed with a cloth lightly dampened with mild detergent solution.

Environment

- Allowed ambient temperature range: $t_a = 5^{\circ}\text{C}$ (41°F) to 40°C (104°F)
- Rated humidity = 10% RH to 80% RH Non-condensed.
- Ensure that nothing can be spilled on, or dropped inside the projector. If this does happen, switch off and remove all power from the projector. Do not operate the projector again until it has been checked by qualified service personnel.
- Do not use this equipment near water.

Air cleanness

- The projector must be installed in environments where the amount of dust particles is as low as expected in a standard office environment.
- The environment must be clean and free from hostile airborne particles which may have harmful effects, such as – and not limited to - airborne contaminants produced by smoke or snow machines, contaminants

derived from chemical products such as (and not limited to) disinfectants, conducting types of dust, excessive dust.

- These contaminants deposit a thin layer of greasy residue on the projectors internal optics and electronic boards, degrading performance and leading to failures.
 - Damage of this nature is under no circumstances covered under the manufacturer's warranty and may deem the warranty null and void.
 - The manufacturer reserves the right to refuse repair if a projector has been subject to knowingly neglect, abandon or improper use.
 - If the specified environmental conditions cannot be guaranteed, the projector must be removed, or switched off and fully protected until the requirements are fulfilled.
 - Devices or structures to extract or shield contaminated air well away from the projector are a prerequisite, if this is not a feasible solution then the projector must be relocated to a clean air environment
 - Failure to take suitable precautions to protect the projector from the effects of air contaminants as mentioned above will culminate in extensive and irreversible damage.

Cooling

- The projector must always be installed in a manner which ensures free flow of air into its air inlets.
- Do not block the projector cooling fans or free air movement around the projector.
- Slots and openings in the cabinet are provided for ventilation. To ensure reliable operation of the product and to protect it from overheating, these openings must not be blocked or covered. The openings should never be blocked by placing the product on a bed, sofa, rug, or other similar surface. This product should never be placed near or over a radiator or heat register. The device should not be placed in a built-in installation or enclosure unless proper ventilation is provided.
- If more than one projector is installed in a common projection booth, the exhaust air flow requirements are valid for EACH individual projector system. Note that inadequate air extraction or cooling will result in decreased life expectancy of the projector as a whole as well as causing premature failure of the lasers.
- The air filters of the projector must be cleaned or replaced on a regular basis. Cleaning the booth area would be monthly-minimum. Neglecting this could result in disrupting the air flow inside the projector, causing overheating. Overheating may lead to the projector shutting down during operation.
- In order to ensure that correct airflow is maintained, and that the projector complies with Electromagnetic Compatibility (EMC) and safety requirements, it should always be operated with all of it's covers in place.

DMD protection

- Special care should be used when DLP projectors are used in the same room as high power laser equipment. Direct or indirect hitting of a laser beam on to the lens can severely damage the Digital Mirror Devices™ in which case there is a loss of warranty.
- Never place the projector in direct sunlight. Sunlight on the lens can severely damage the Digital Mirror Devices™ in which case there is a loss of warranty.
- Add the optional external shutter to protect the projector optics from other light sources (e.g. direct sunlight, other laser light sources, etc) when the projector light source is off.

Operation

- Only use Barco projection lenses that are supported for the I600. Using other lenses will damage the internal optics. For suitable lenses contact Barco or see Barco website.
- To ensure the highest optical performance and resolution, the projection lenses are specially treated with an anti-reflective coating, therefore, avoid touching the lens. To remove dust on the lens, use a soft dry cloth. For lens cleaning follow the instructions precisely as stipulated in the projector manual.

Shipment

- Save the original shipping carton and packing material. They will come in handy if you ever have to ship your equipment. For maximum protection, repack your set as it was originally packed at the factory.

On servicing

- Do not attempt to service this product yourself, as opening or removing covers may expose you to dangerous voltage potentials and risk of electric shock.
- Refer all servicing to qualified service personnel.
- Attempts to alter the factory-set internal controls or to change other control settings not specially discussed in this manual can lead to permanent damage to the unit and cancellation of the warranty.

- Replacement parts: When replacement parts are required, be sure the service technician has used original Barco replacement parts or authorized replacement parts which have the same characteristics as the Barco original part. Unauthorized substitutions may result in degraded performance and reliability, fire, electric shock or other hazards. Unauthorized substitutions may void warranty.
- Safety check: Upon completion of any service or repairs to this unit, ask the service technician to perform safety checks to determine that the product is in proper operating condition.

Malfunction unit

Remove all power from the product and refer servicing to qualified service technicians under the following conditions:

- When the power cord or plug is damaged or frayed.
- If liquid has been spilled into the equipment.
- If the product has been exposed to rain or water.
- If the product does not operate normally when the operating instructions are followed. Adjust only those controls that are covered by the operating instructions since improper adjustment of the other controls may result in damage and will often require extensive work by a qualified technician to restore the product to normal operation.
- If the product has been dropped or the cabinet has been damaged.
- If the product exhibits a distinct change in performance, indicating a need for service.

Stacking and transporting

- Stack maximum 2 rental flight cases high. Never higher.
- Surface on which flight case is standing must be level to ensure that the total load is evenly spread out among the four wheels. The surface must also be able to support the load safely.
- Before stacking or transporting flight cases, check the wheels and their fixation screws for wear or defects.
- Before stacking or transporting flight cases, check that the four lock handles on each flight case are in good working order and locked securely.
- When stacked, make sure the wheels of the upper flight case are precisely positioned in the stacking dishes of the flight case below.
- Stacked flight cases may not be moved. Before stacking, the lower flight case must already be in its final resting position before placing the second upon it.
- Never stack loaded flight cases in a truck or other transport medium, unless each flight case is rigidly strapped tight.
- In the event of a wheel breaking, flight cases must be rigidly strapped tight to prevent a stack collapsing.
- Use an appropriate forklift to raise flight cases and take the necessary precautions to avoid personnel injury.



Safety Data Sheets for Hazardous Chemicals

For safe handling information on chemical products, consult the Safety Data Sheet (SDS). SDSs are available upon request via safetydatasheets@barco.com.

1.3 Product safety labels

Light beam related safety labels

Safety labels explanation and location:

Refer to user manual for further information!	
Hazard RG3: Not for household use symbol.	

Hazard RG3:
Optical radiation warning symbol.



<p>WARNING! DO NOT LOOK INTO THE BEAM. NO DIRECT EYE EXPOSURE TO THE BEAM IS PERMITTED. CLASS 1 LASER PRODUCT RG3. HAZARD DISTANCE: REFER TO THE SAFETY MANUAL.</p> <p>IEC 60825-1:2014 CAN/CSA-E60825-1:15 EN 60825-1:2014+ A11: 2021 EN/IEC 62471-5:2015</p> <p>警告! 請勿直視光束。眼睛不要直接曝露在光束中 1類激光產品RG3 危害距離: 參見用戶手冊</p> <p>IEC 60825-1:2014 CAN/CSA-E60825-1:15 EN 60825-1:2014+ A11: 2021 EN/IEC 62471-5:2015</p>	<p>ATTENTION! NE PAS REGARDER LE FAISCEAU. EVITER TOUTE EXPOSITION DIRECTE DES YEUX AU FAISCEAU. PRODUIT LASER DE CLASSE 1 RG3. DISTANCE DE SECURITE: CONSULTER LE MANUEL DE SECURITE.</p> <p>IEC 60825-1:2014 CAN/CSA-E60825-1:15 EN 60825-1:2014+ A11: 2021 EN/IEC 62471-5:2015</p> <p>警告! 請勿注視光源。禁止眼睛曝露在光源照射範圍 雷射危險等級: 1類雷射產品RG3 安全危害距離: 請參考安全手冊</p> <p>IEC 60825-1:2014 CAN/CSA-E60825-1:15 EN 60825-1:2014+ A11: 2021 EN/IEC 62471-5:2015</p>
<p>THIS PRODUCT IS IN CONFORMITY WITH PERFORMANCE STANDARDS FOR LASER PRODUCTS UNDER 21 CFR 1040, EXCEPT WITH RESPECT TO THOSE CHARACTERISTICS AUTHORIZED BY VARIANCE NUMBER 2016-V-0144 EFFECTIVE ON DECEMBER 12, 2019.</p>	
<p>WARNING! DO NOT LOOK INTO THE BEAM. NO DIRECT EYE EXPOSURE TO THE BEAM IS PERMITTED. CLASS 1 LASER PRODUCT RG3. HAZARD DISTANCE: REFER TO THE SAFETY MANUAL.</p> <p>ATTENTION! NE PAS REGARDER LE FAISCEAU. EVITER TOUTE EXPOSITION DIRECTE DES YEUX AU FAISCEAU. PRODUIT LASER DE CLASSE 1 RG3. DISTANCE DE SECURITE: CONSULTER LE MANUEL DE SECURITE.</p> <p>警告! 請勿直視光束。眼睛不要直接曝露在光束中 1類激光產品RG3 危害距離: 參見用戶手冊</p> <p>警告! 請勿注視光源。禁止眼睛曝露在光源照射範圍雷射危險等級: 1類雷射產品RG3 安全危害距離: 請參考安全手冊</p> <p>IEC 60825-1:2014 EN 60825-1: 2014+ A11: 2021 CAN/CSA-E60825-1: 15 EN/IEC 62471-5:2015</p> <p>THIS PRODUCT IS IN CONFORMITY WITH PERFORMANCE STANDARDS FOR LASER PRODUCTS UNDER 21 CFR 1040, EXCEPT WITH RESPECT TO THOSE CHARACTERISTICS AUTHORIZED BY VARIANCE NUMBER 2016-V-0144 EFFECTIVE DECEMBER 12, 2019.</p> <p>EMC This is a Class A product. In a domestic environment this product may cause radio interference in which case the user may be required to take adequate measures.</p> <p>警告: 此為A級產品, 在居住環境中, 運行此設備可能會造成無線電干擾。</p> <p>警告使用者: 此為甲類資訊技術設備, 於居住環境中使用時, 可能會造成射頻擾動, 在此種情況下, 使用者會被要求採取某些適當的對策。</p> <p>CANADA This Class A digital apparatus complies with the Canadian ICES-003. Cet appareil numérique de la Classe A est conforme à la norme NMB-003 du Canada.</p>	

1.4 High Brightness precautions: Hazard Distance

i HD
Hazard Distance (HD) is the distance measured from the projection lens at which the intensity or the energy per surface unit becomes lower than the applicable exposure limit on the eye or on the skin. The light beam is considered (to be) unsafe for exposure if the distance from a person to the light source is less than the HD.

Restriction Zone (RZ) based on the HD

The HD depends on the amount of lumens produced by the projector and the type of lens installed. See chapter “HD in function of modifying optics”, page 20.

To protect untrained end users (as venue visitors, spectators) the installation shall comply with the following installation requirements: Operators shall control access to the beam within the hazard distance or install the product at a height that will prevent spectators' eyes from being in the hazard distance. Radiation levels in excess of the limits will not be permitted at any point less than 2.0 meter (SH) above any surface upon which persons other than operators, performers, or employees are permitted to stand or less than 1.0 meter (SW) lateral separation from any place where such persons are permitted to be. In environments where unrestrained behavior is reasonably foreseeable, the minimum separation height should be greater than or

equal to 3.0 meter to prevent potential exposure, for example by an individual sitting on another individual's shoulders, within the HD.

These values are minimum values and are based on the guidance provided in IEC 62471-5:2015 section 6.6.3.5.

The installer and user must understand the risk and apply protective measures based upon the hazard distance as indicated on the label and in the user information. Installation method, separation height, barriers, detection system or other applicable control measure shall prevent hazardous eye access to the radiation within the hazard distance.

For example, projectors that have a HD greater than 1 m and emit light into an uncontrolled area where persons may be present should be positioned in accordance with “the fixed projector installation” parameters, resulting in a HD that does not extend into the audience area unless the beam is at least 2.0 meter above the floor level. In environments where unrestrained behavior is reasonably foreseeable, the minimum separation height should be greater than or equal to 3.0 meter to prevent potential exposure, for example by an individual sitting on another individual's shoulders, within the HD. Sufficiently large separation height may be achieved by mounting the image projector on the ceiling or through the use of physical barriers.

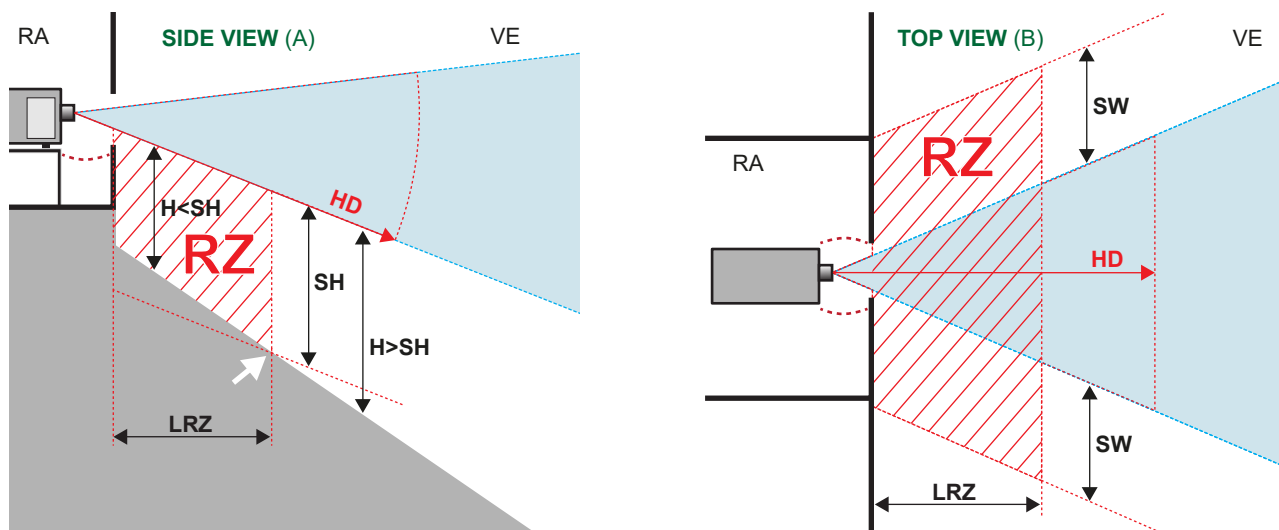

Image 1-1

- A** Side view
- B** Top view
- RA** Restricted Access location (boot area of projector).
- VE** Venue
- RZ** Restriction Zone

- HD** Hazard Distance
- LRZ** Length Restriction Zone
- H** Height between surface floor and the light beam
- SH** Separation Height
- SW** Separation Width

Based on national requirements, no person is allowed to enter the projected beam within the zone between the projection lens and the related hazard distance (HD). This shall be physically impossible by creating sufficient separation height or by placing barriers. The minimum separation height takes into account the surface upon which persons other than operator, performers or employees are permitted to stand.

On [Image 1-2](#) a typical setup is displayed. It must be verified if these minimum requirements are met. If required a restricted zone (RZ) in the venue must be established. This can be done by using physical barrier, like a red rope as illustrated in [Image 1-2](#).

The restricted area sticker can be replaced by a sticker with only the symbol.

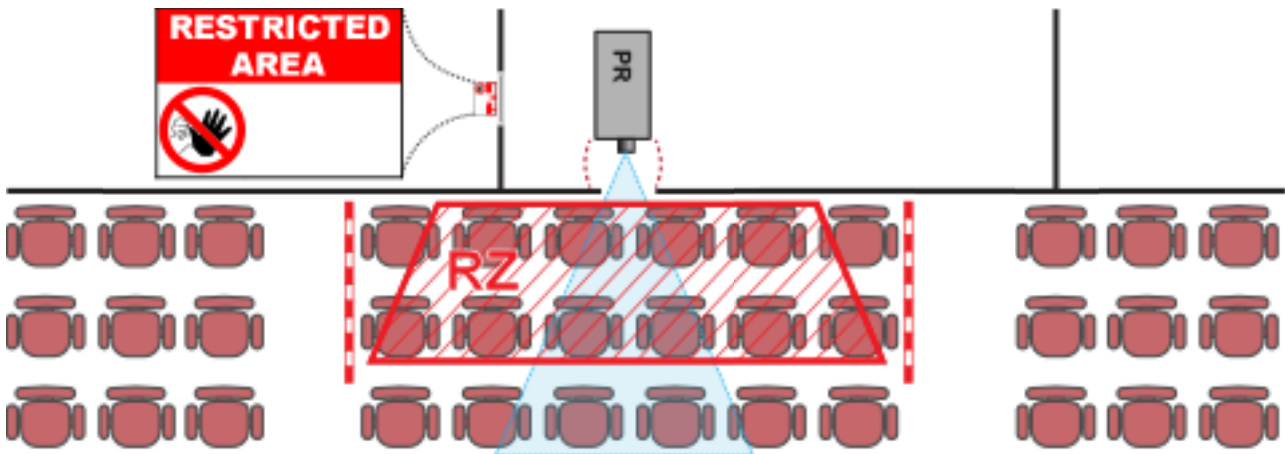

Image 1–2

USA market

For LIPs (Laser Illuminated Projectors) installed in the USA market other restriction zone conditions apply.

LIPs for installation in restrained environment (cinema theaters, business rooms, class rooms, museums ...) shall be installed at height vertically above the floor such that the bottom plane of the hazard distance zone shall be no lower than 2.5 meters above the floor. Horizontal clearance to the hazard distance zone shall be not less than 1 meter. Alternatively, in case the height of the separation barrier for the horizontal clearance is at least 1 meter high then the horizontal clearance (SW) can be reduced to:

- 0 meter if the height of the hazard zone is minimum 2.5 meter.
- 0.1 meter if the height of the hazard zone is minimum 2.4 meter.
- 0.6 meter if the height of the hazard zone is minimum 2.2 meter.

LIPs for installations in unrestrained environment (concerts, ...) shall be installed at a height vertically above the floor such that the bottom plane of the Hazard distance Zone shall be no lower than 3 meters above the floor. Horizontal clearance to the hazard distance zone shall be not less than 2.5 meters. Any human access horizontally to the Hazard Zone, if applicable, shall be restricted by barriers. If human access is possible in an unsupervised environment, the horizontal or vertical clearances shall be increased to prevent exposure to the hazard distance zone.

The LIP shall be installed by Barco or by a trained and Barco-authorized installer or shall only be transferred to laser light show variance holders. This is applicable for dealers and distributors since they may need to install the LIP (demo install) and/or they transfer (sell, rent, lease) the LIP. Dealers and distributors shall preserve sales and installation records for a period of 5 years. Variance holders may currently hold a variance for production of Class IIIB and IV laser light shows and/or for incorporating RG3 LIPs. Laser light show variance for RG3 LIPs can be requested by mailing the application to RadHealthCustomerService@fda.hhs.gov.

The installation checklist for laser illuminated RG3 projectors must be fully completed after the installation. The installation checklist can be downloaded from the Barco website. The installer shall preserve the checklist for a period of 5 years. A copy can remain on-site.

Install one or more readily accessible controls to immediately terminate LIP projection light. The power input at the projector side is considered as a reliable disconnect device. When required to switch off the projector, disconnect the power cord at the projector side. In case the power input at the projector side is not accessible (e.g. truss mount), the socket outlet supplying the projector shall be installed nearby the projector and be easily accessible, or a readily accessible general disconnect device shall be incorporated in the fixed wiring.

1.5 HD for fully enclosed projection systems



HD

Hazard Distance (HD) is the distance measured from the projection lens at which the intensity or the energy per surface unit becomes lower than the applicable exposure limit on the eye or on the skin. The light beam is considered (to be) unsafe for exposure if the distance from a person to the light source is less than the HD.

Restriction Zone (RZ) based on the HD

The projector is also suitable for rear projection applications; projecting a beam onto a diffuse coated projection screen. As displayed in following graphic, two areas should be considered: the restricted enclosed projection area (RA) and the observation area (VE).

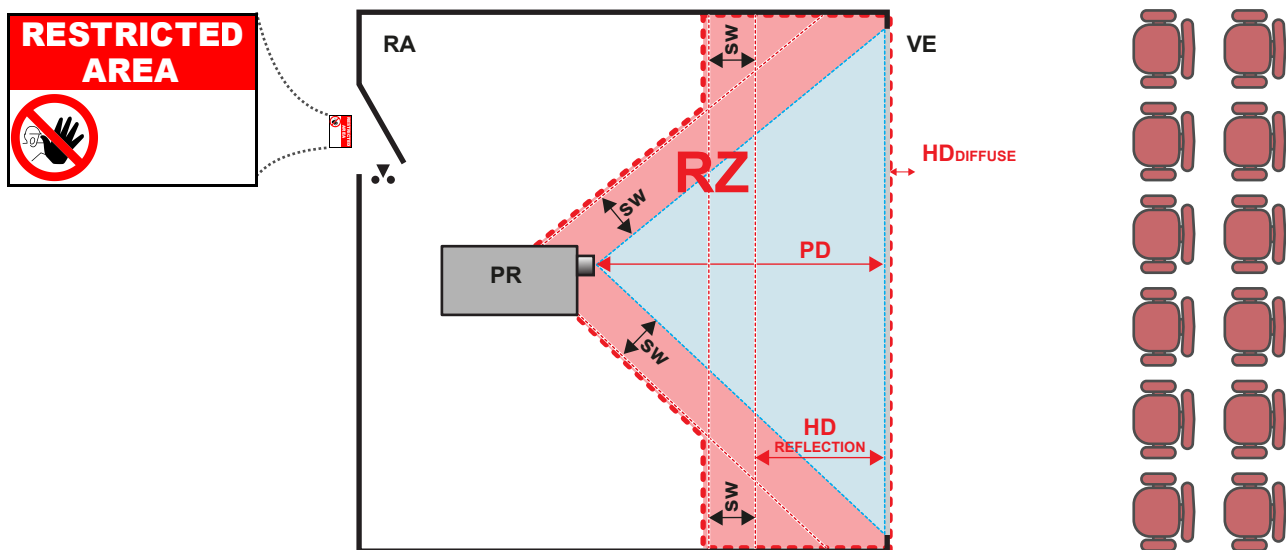

Image 1-3

RA Restricted Access location (enclosed projection area).
PR Projector.
VE Venue (observation area).

RZ Restriction Zone.
PD Projection Distance.
SW Separation Width. Must be minimum 1 meter.

For this type of setup 3 different HD shall be considered:

- HD as discussed in “High Brightness precautions: Hazard Distance”, page 16, relevant for intrabeam exposure.
- $HD_{\text{reflection}}$: the distance that has to be kept restrictive related to the reflected light from the rear projection screen.
- HD_{diffuse} : the relevant distance to be considered while observing the diffuse surface of the rear projection screen.

As described in “High Brightness precautions: Hazard Distance”, page 16, it is mandatory to create a restricted zone within the beam areas closer than any HD. In the enclosed projection area the combination of two restricted zones are relevant: The restricted zone of the projected beam toward the screen; taking into account 1 meter Separation Width (SW) from the beam onward. Combined with the restricted zone related to the rear reflection from the screen ($HD_{\text{reflection}}$); also taking into account a 1 meter lateral separation.

The $HD_{\text{reflection}}$ distance equals 25% of the difference between the determined HD distance and the projection distance to the rear projection screen. To determine the HD distance for the used lens and projector model see chapter “HD in function of modifying optics”, page 20.

$$HD_{\text{reflection}} = 25\% (HD - PD)$$

The light emitted from the screen within the observation shall never exceed the RG2 exposure limit, determined at 10 cm. The HD_{diffuse} can be neglected if the measured light at the screen surface is below 5000 cd/m² or 15000 LUX.

1.6 HD in function of modifying optics

Hazard distance

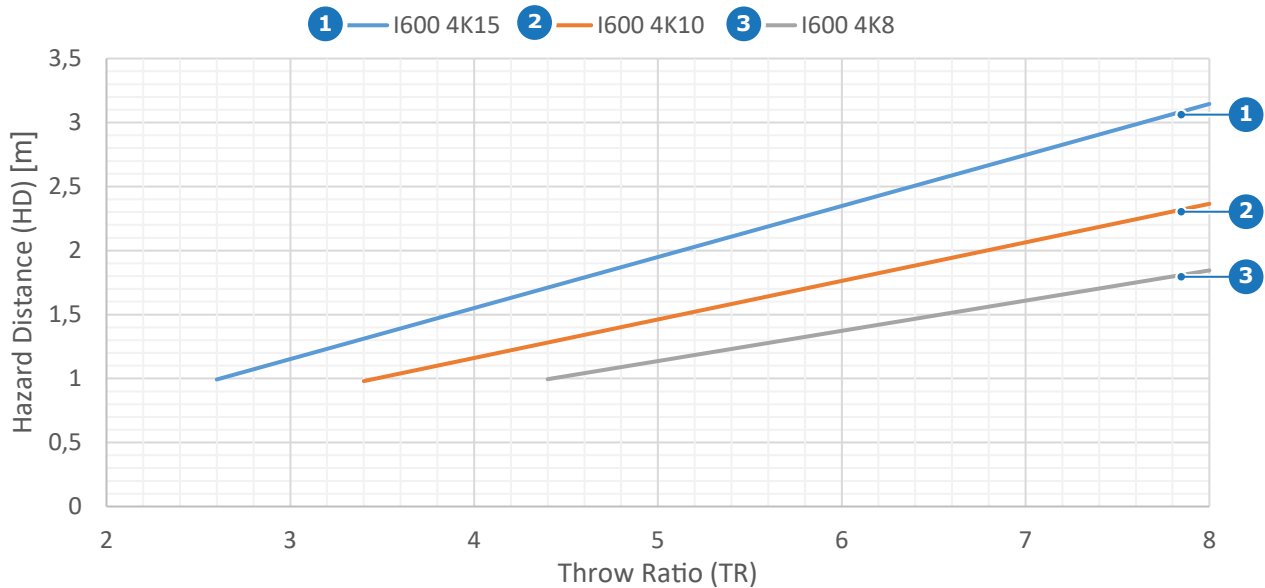

Image 1–4

HD Hazard Distance
TR Throw Ratio



No hazard distance measures required when the hazard distance is shorter than 1 meter. Do not stare into the beam and prevent close exposure to children.

1.7 HD calculation of multi-projector stacks

Sometimes two or more projectors are stacked (projecting on the same surface). In this case, because of the overlap of the images, possibly a system Hazard Distance needs to be applied instead of a single projector hazard distance.

Only projectors stacked along one axis (horizontal or vertical) should be considered. Physical stacking of projectors in two dimensions (for example 2x2), can be reduced to separate “N”x1 systems.

The information needed is:

- The Hazard Distance (**HD**) of a single projector with the given lens.
- The distance (**h**) between two adjacent projector lens centers in the stack.



For 3 or more projectors, in case the distances between adjacent lenses are not equal, take the shortest distance.

HD calculation:

- For stacking two-projectors:
 - **If the single projector hazard distance $HD \geq 9 \cdot h$** , then the system hazard distance to implement is $1.15 \cdot HD$.
 - **If the single projector hazard distance $HD < 9 \cdot h$** , then keep the original HD and risk zone per projector.
- For stacking “N” projectors along the same axis, “N” being 3 or more:
 - **If the single projector hazard distance $HD \geq 12 \cdot h$** , then the system hazard distance to implement is $(\frac{N}{2} + 0.15) \cdot HD$.
 - **If the single projector hazard distance $9 \cdot h \leq HD < 12 \cdot h$** , then the system hazard distance to implement is $1.15 \cdot HD$.

- If the single projector hazard distance $HD < 9 \cdot h$, then keep the original HD and risk zone per projector.

1.8 Compliance

UK Compliance



This product is fit for use in the UK.

Authorised Representative: Barco UK Ltd

Address: Building 329, Doncastle Road
Bracknell RG12 8PE, Berkshire, United Kingdom

L'information des consommateurs sur la règle de tri



1.9 Download Product Manual

Download product manual

Product manuals and other related documentation are available online at <https://www.barco.com>. Search or browse to the product support page or scan the QR code on the product ID-label or on the box label. To see all service documentation (e. g., spare part list, service manuals, field loadable software ...) you must be registered and logged in.

IMPORTANT! Read Installation instructions before connecting equipment to the mains power supply.

I600 introduction

2

2.1	Projector orientation.....	24
2.2	Projector components.....	24
2.3	Projector airflow.....	24
2.4	Projector status.....	25
2.5	Pulse Prospector.....	26

About this chapter

This chapter and by extension this whole document, the **I600 user guide**, is intended for the user who want to get familiar with the projector hardware parts. It describes the input and communication boards, the remote control unit, local keypad, how to power up the projector, the different power states, product specifications and much more. It does not contain installation instructions and does not describe the Pulse graphic user interface. Refer to the **I600 installation manual** for detailed installation instructions and to the **Pulse OSD user guide** for all software features of the projector.



The Pulse software has regular new releases due to continuous improvements. Hence, the **Pulse OSD** user guide is subject to updates. Download the latest version of the user guide from the Barco website using following link: <https://www.barco.com/support>.



For detailed product specifications see the appendix chapters: “**Specifications**”, page 63, and following.

2.1 Projector orientation

Orientation convention

This manual refers to the left side of the projector as the side at your left hand when standing behind the projector and looking at the projection screen in front of the projector.

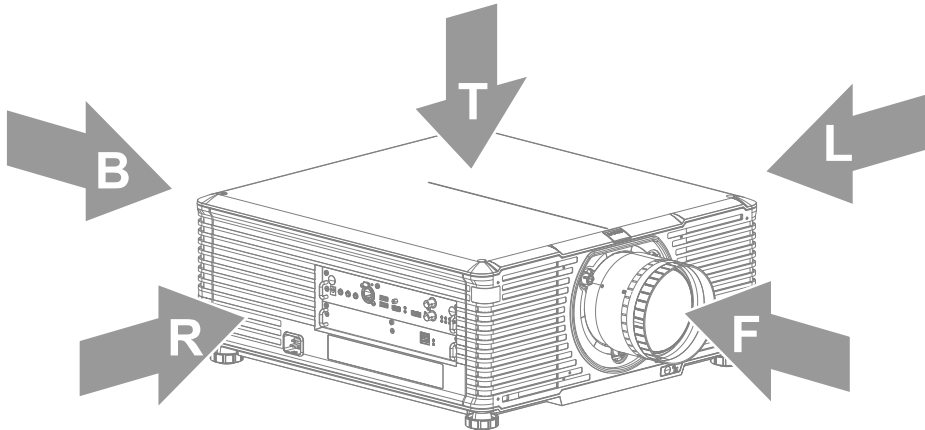

Image 2-1

T Top
L Left
F Front

R Right
B Back

2.2 Projector components

Component location

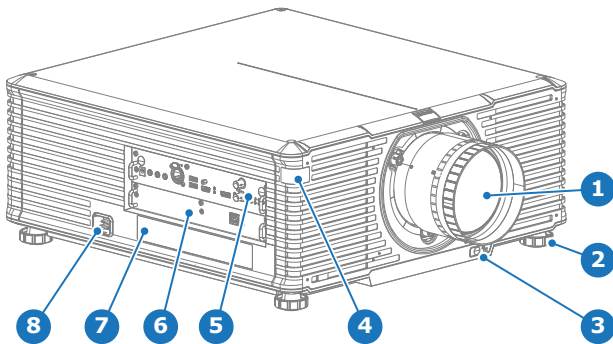

Image 2-2

1 Projection lens
2 Adjustable feet (x4)
3 Lens unlock button
4 Infra Red receiver front
5 Control & Communication
6 Optional input slot
7 Product ID label
8 Mains input socket

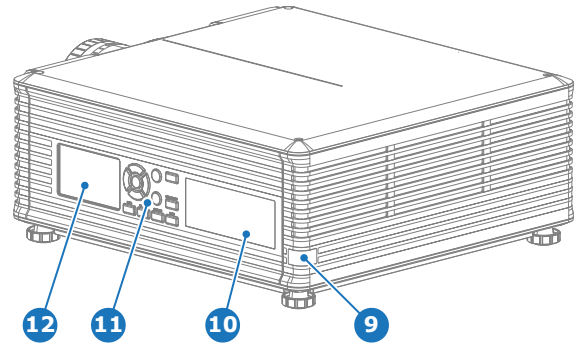

Image 2-3

9 Infra Red receiver back
10 Safety label
11 Local keypad
12 LCD touch panel

2.3 Projector airflow

Air inlets and outlets

The projector has 1 air inlet channel and 1 air outlet. The air outlet is located at the front side of the projector. The air inlet is located at the back side of the projector.

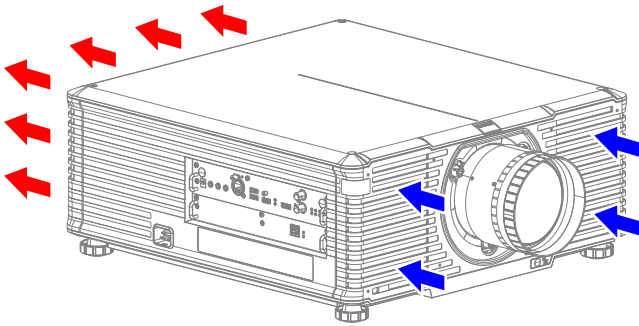

Image 2-4

CAUTION: Never block the air inlets or outlets of the projector. Always ensure that clean cool air, compliant with the specified ambient temperature, can freely enter the air inlets of the projector.

2.4 Projector status

Projector status indicator LEDs

The Control & Communication module contains four status LEDs at the right side of the front panel. These LEDs allows a quick status analyses of the projector. For explanatory see table hereunder.

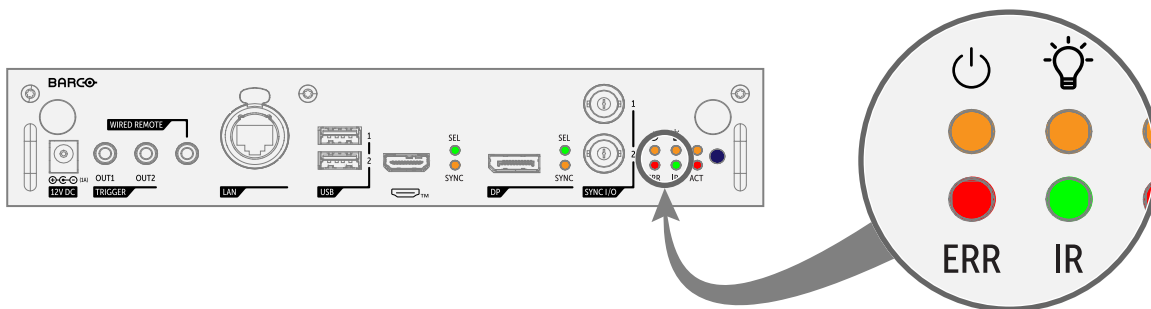



Image 2-5 Location of projector status LEDs.

LED	Color status	Description
 Power	Off	Projector is in ECO STANDBY mode, or is powering up
	RED	Projector is in STANDBY mode
	ORANGE	Projector is in READY mode
	GREEN	Projector is ON
 Illumination	Off	Light source is OFF
	RED	No light source detected
	ORANGE	Light source is on in ECO mode
	GREEN	Light source is on in normal mode
	GREEN-ORANGE	Light source is on in CLO mode
ERR	Off	No error
	RED toggles on/off	Error
	ORANGE toggles on/off	Warning
IR	RED	IR signal received
	GREEN	IR signal acknowledged

2.5 Pulse Prospector

About Pulse Prospector

Pulse Prospector is a built-in web application in the projector. The application provides all the necessary tools to configure and control the connected projector remotely. It is readily available on the connected projector without any additional software installation. It is accessible via a web browser and is fully supported on iOS and Android devices.

Pulse Prospector is supported from projector software version 2.5 onwards.

Prerequisites

- Projector software package 2.5 or later must be installed.
- In order to connect a device (e.g., laptop) with the projector, both the device and the projector must operate within the same network (or the device needs to have full access to the projector network).



It is recommended to upgrade the web browser to the latest version available for the best viewing experience, compatibility and security.

How to connect with Pulse Prospector

1. Start a web browser.
2. Enter the IP address of the projector in the address bar of the browser and confirm.



Tip: The projector IP address is visible on the Dashboard of the projector LCD touch panel.



Note: Depending on the configuration of the browser, a security warning could be displayed. To prevent this warning in the future, the product certificate must be trusted as a root certificate in the browser. For more info, contact the local IT responsible.

Depending on the projector model and installed Pulse software version, either the Pulse Prospector login page or home page is displayed.

Pulse Prospector user guide

All features of the Pulse Prospector are described in a separate user guide which is applicable for all Pulse based projectors. Hence, each menu or menu group in the user guide is preceded with a “**Location and availability**” section wherein the relevant projector models and accounts are mentioned.

The Pulse software has regular new releases due to continuous improvements. Hence, the Pulse Prospector user guide is subject to updates. Download the latest version of the user guide from the Barco website using following link: <https://www.barco.com/support>.

3

Local keypad

3.1	Local keypad functions.....	28
3.2	Local keypad backlight.....	28
3.3	LCD touch panel.....	29

3.1 Local keypad functions

Local keypad overview

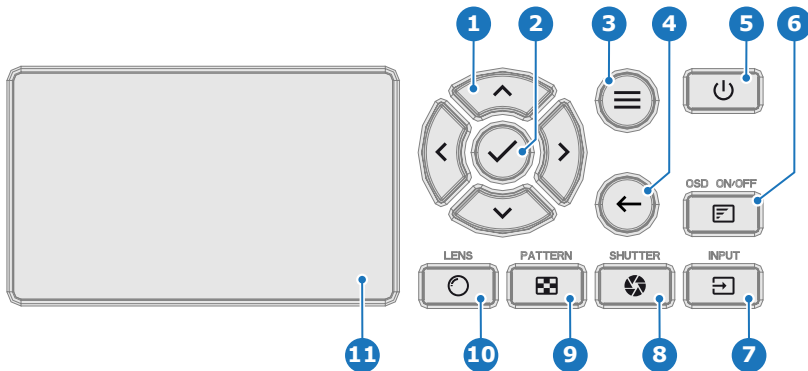

Image 3-1

- | | | | |
|---|-----------------|----|--------------------|
| 1 | Navigation | 7 | Input selection |
| 2 | Confirmation | 8 | Shutter open/close |
| 3 | Menu enter/exit | 9 | Test patterns |
| 4 | Menu back | 10 | Lens menu |
| 5 | Power On/Off | 11 | LCD touch panel |
| 6 | OSD On/Off | | |

Functionality

The local keypad gives direct access to several functions, in addition, access to the Pulse menu system.

The local keypad has a backlight that can be switched on and off manually. By default the light turns off after 5 minutes.



Refer to the **Pulse OSD** user guide for detailed guidance on all software features of the projector.





The Pulse software has regular new releases due to continuous improvements. Hence, the **Pulse OSD** user guide is subject to updates. Download the latest version of the user guide from the Barco website using following link: <https://www.barco.com/support>.

3.2 Local keypad backlight

Button backlight status

The **Power** and **Shutter** buttons are equipped with white, blue and red backlit LEDs. The other keys are only equipped with white and blue backlit LEDs. The LEDs are controlled according to the features available.

Button	Color status	Description
	Short WHITE pulse	Projector starts up (booting), or is in ECO STANDBY
	Blinking WHITE	Firmware update, or in transition from ECO STANBY to STANDBY
	Solid WHITE	Projector is in STANDBY or READY mode
	Blinking BLUE	Projector goes to ON mode
	Solid BLUE	Projector is ON
	Blinking RED	Error condition
	Off (no color)	Projector is OFF, starts up, or is in STANDBY or READY mode
	Solid WHITE	Projector is ON, shutter is open
	Solid RED	Projector is ON, shutter is closed

3.3 LCD touch panel

Functionality

The LCD touch panel has two main functions:

1. Showing the menus, adjustment information and if enabled a mirror of the OSD (On Screen Display).
2. Information regarding the status of the projector:
 - Projector status
 - Network address
 - Active source
 - Current firmware version
 - Operation Data
 - Active functions (Enabled Functions).

Toggle between the two main function by using the **Menu** button on the local keypad, or on the remote control unit.

The LCD touch panel will fade out 30 seconds after the last key operation.

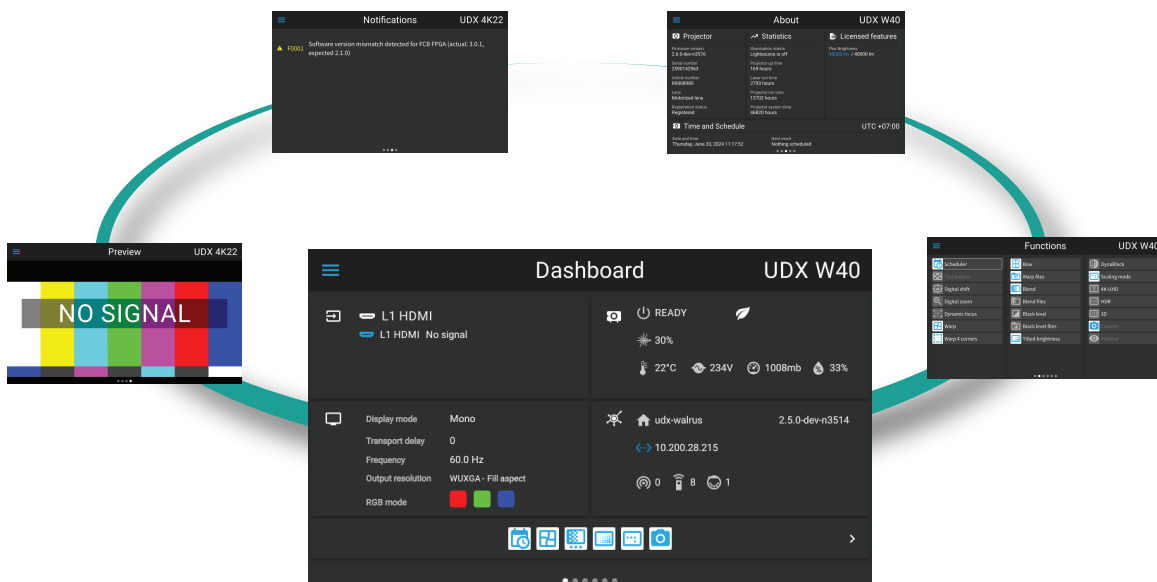

Image 3–2 Example of the Pulse OSD user interface



Refer to the **Pulse OSD** user guide for detailed guidance on all software features of the projector.

Navigation

Use the arrow keys on the local keypad or on the remote control unit to navigate through the menus on the LCD touch panel.

In addition to the remote control unit and the local keypad, it is also possible to navigate in the menus with the touch functionality in the LCD panel:

- Press the icons to select the functions.
- Select switches to toggle.
- Select and drag sliders to adjust slider value.



The LCD menus can occasionally be slightly different in layout compared with the OSD menu, due to a more optimal layout regarding to the touch functionality of the LCD.

Basic Remote Control Unit

4

4.1	Basic remote functions	32
4.2	Basic remote batteries	32

About the basic remote

The I600 projector is standard delivered with a basic remote control unit (without batteries). While this remote control unit has a more limited amount of available features compared with the optional Pulse RCU, it will be able to help you out with basic controls.



For more information about the optional Pulse RCU see chapter [“Pulse Remote Control Unit”](#), page 35. For ordering information see Barco website.

4.1 Basic remote functions

Functions

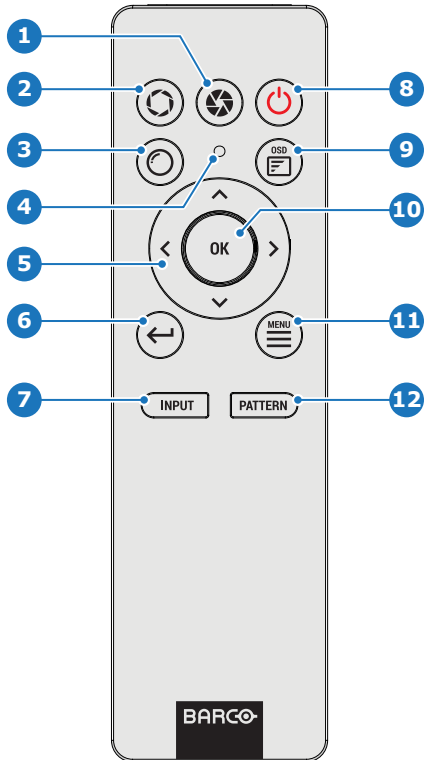

Image 4-1

- | | | | |
|---|------------------------------------|----|-------------------------------|
| 1 | Close shutter | 7 | Open <i>Source</i> menu |
| 2 | Open shutter | 8 | Power on / off |
| 3 | Open <i>Lens</i> menu | 9 | OSD menu on / off |
| 4 | Button pressed indicator | 10 | Menu confirmation |
| 5 | Menu navigation keys | 11 | GUI activate / deactivate |
| 6 | Move back one level in menu system | 12 | Open <i>Test pattern</i> menu |



The Power on / off button only shifts power between Ready and ON mode.



When pressing the GUI activate / deactivate button while the projector is in stand-by mode, will also power up the projector.

4.2 Basic remote batteries

Battery placement & replacement

The basic remote control is powered by two (2) standard AAA batteries. The needed batteries are not included in the packaging.

The battery compartment is on the back side of the basic remote control. The following image illustrates how to open the battery compartment.

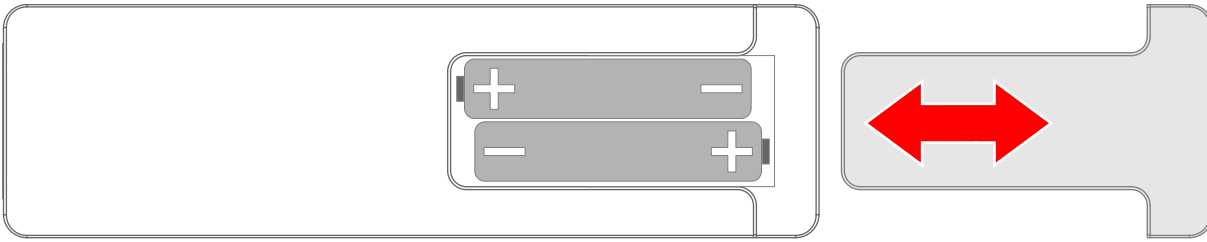

Image 4-2 Position of batteries in basic remote.



CAUTION: Replace batteries with the correct battery type. Only use AAA size batteries. There is a risk of explosion if the battery is replaced with an incorrect type.

Make sure the polarities match the + and - marks, as depicted on the inside of the battery compartment. There is a risk of explosion if the batteries are installed incorrectly.

Pulse Remote Control Unit

5

5.1	Pulse RCU functions	36
5.2	Pulse RCU battery installation	36
5.3	Pulse RCU on/off button.....	37
5.4	Pulse RCU “button pressed indicator”	38
5.5	Pulse RCU “RGB filter” button	38
5.6	Pulse RCU “Projector OSD on/off” button	39
5.7	Using the XLR connector of the RCU	39
5.8	Using the mini-jack connector of the RCU.....	39
5.9	Pulse RCU silicone protection sleeve (optional)	40

5.1 Pulse RCU functions

Functions

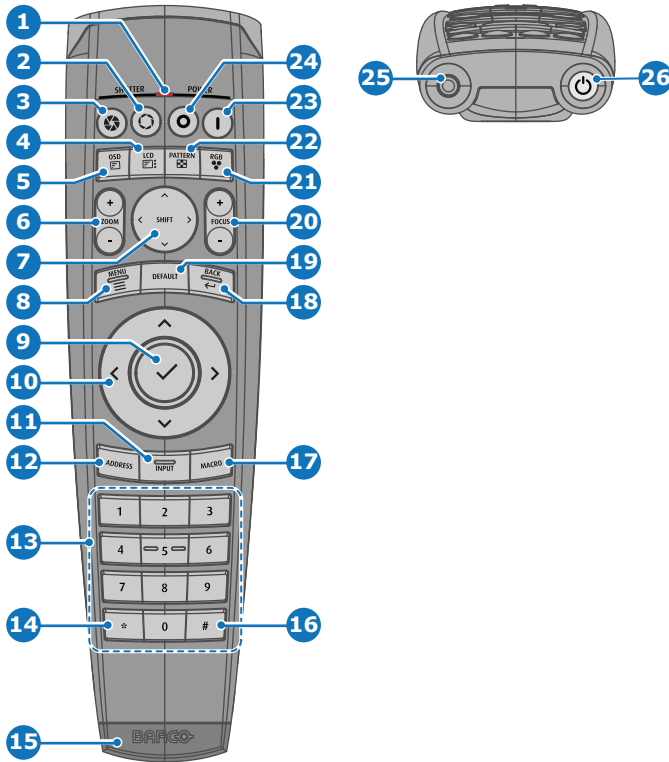

Image 5-1

- | | | | |
|----|---------------------------|----|--------------------------------------|
| 1 | Button pressed indicator | 14 | Backspace (while entering values) |
| 2 | Shutter open | 15 | XLR connector |
| 3 | Shutter close | 16 | Decimal mark (while entering values) |
| 4 | LCD/Touch panel on / off | 17 | Macro button (Not in use) |
| 5 | Projector OSD on / off | 18 | Menu back |
| 6 | Lens zoom | 19 | Default value button |
| 7 | Lens shift | 20 | Lens focus |
| 8 | Menu open / close | 21 | RGB filter |
| 9 | Menu selection, OK button | 22 | Test patterns |
| 10 | Menu navigation | 23 | Power on |
| 11 | Input selection | 24 | Power off |
| 12 | Address button | 25 | 3.5 mm jack |
| 13 | Numeric buttons | 26 | RCU on / off |

5.2 Pulse RCU battery installation

About the batteries for the remote control



Due to updated shipping regulations, batteries are no longer included in the packaging. It is up to the user to purchase the correct batteries. Use two AA size (alkaline) batteries in the remote control.

Install the batteries before using the Pulse RCU.



CAUTION: Replace with the correct battery type. Use two AA size batteries. There is a risk of explosion if the battery is replaced with an incorrect type.

Required parts

AA size alkaline battery (two pieces)

How to install

1. Push the battery cover tab with the fingernail a little backwards (reference 1) and, at the same time, flip the cover outwards (reference 2).

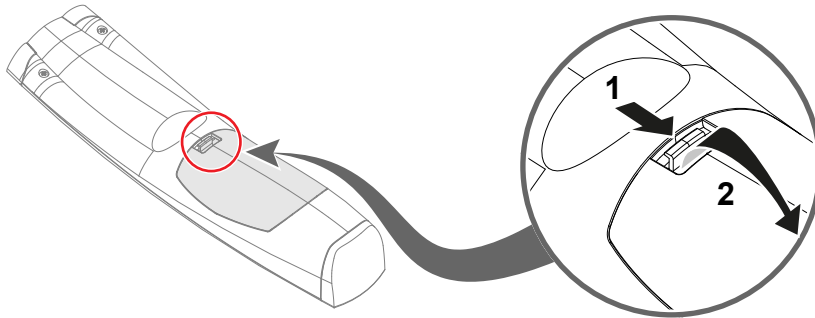



Image 5-2

2. Insert two AA size batteries into the battery compartment, making sure to match the polarities of the batteries to the + and - marks inside the battery compartment.

 **Caution:** Place the batteries as explained. There is a risk of explosion if the battery is incorrectly installed.

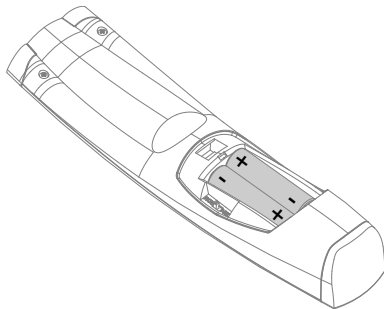

Image 5-3

3. Insert both lower tabs of the battery cover in the gaps at the bottom of the remote control (reference 3).
4. Press the top of the cover until it clicks in place (reference 4).

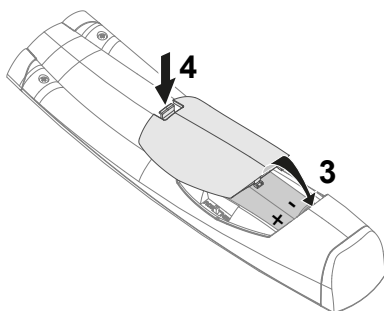

Image 5-4

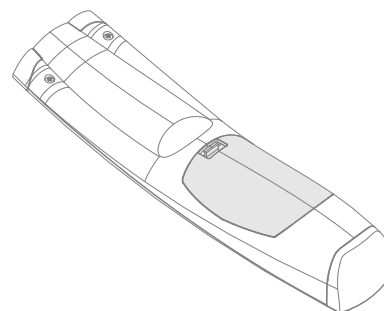

Image 5-5



When replacing batteries, the broadcast address of the RCU will be reset to its default value '0'.

5.3 Pulse RCU on/off button

Function of the remote control on/off button

The Pulse remote control unit has at the front side an on/off button (reference 1 [Image 5-6](#)). Switching off the remote control prevents that unwanted commands are sent due to an accidental key press. Furthermore, switching the RCU off will extend the battery lifetime of the remote control.

To activate the remote control, press the on/off button until the button pressed indicator will turn off (3-5 seconds).

To deactivate the remote control, press the on/off button again.

Default after (re)placing batteries, is "ON".

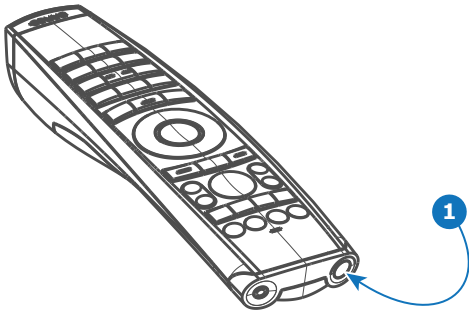

Image 5-6

5.4 Pulse RCU "button pressed indicator"

Functions button pressed indicator

- Rapidly flashes when commands are sent, this is the normal "button pressed" indication.
- 1 Short flash when remote control is switched ON by means of the on/off button.
- Continuously lit (up to 5 seconds) when address digits are expected after pressing the ADDR button.
- Slowly flashes (2 times a second) when the battery level is becoming low; typically when more than 85% of the useful life is past.

5.5 Pulse RCU "RGB filter" button

Filtering the color of the projected image

By pressing the RGB filter button on the RCU you can place a color filter on the output of the projector. This feature can be useful during the installation and configuration of a multi-projector or multi-channel setup. By having one projector project a red image and another project a green image, it is easier to spot and adjust the overlap section.

By pressing this button multiple times, you will have different active filters, in the following cycle:

- Red + Green + Blue (default)
- Red only
- Green only
- Blue only
- Red + Green
- Green + Blue
- Red + Blue
- Red + Green + Blue
- etc



After powering up, the colors will always revert back to full RGB.

5.6 Pulse RCU “Projector OSD on/off” button

On-Screen Display (OSD) on/off

While the light source is on, you can toggle the projection of the On-screen display on and off by pressing the projector OSD on/off button.

Stealth mode on/off

Stealth mode is a function where the backlight of the LCD, the backlight of the keypad buttons and the indication LEDs on the communication and input panels can be disabled.

If “*Stealth mode*” has been enabled in the Pulse software, pressing the OSD on/off button for five seconds or more will cause Stealth mode to activate or deactivate.

For more info on how to configure stealth mode, see the Pulse OSD software user guide or the Pulse Prospector user guide.

5.7 Using the XLR connector of the RCU



Connecting a cable with the XLR connector will reset the broadcast address of the RCU to its default value '0'.

Revised RCU

Revised Remote Control Units produced from April 2023 onward will require the projector to run software 2.3.x (or newer) in order to properly use the XLR connector. If not yet updated to the most recent version, update the projector software. For more information, see [“Software update”](#), page 60.

How to use the XLR connector

1. Pull the XLR cover backwards.

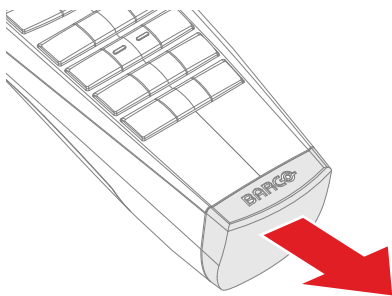

Image 5-7

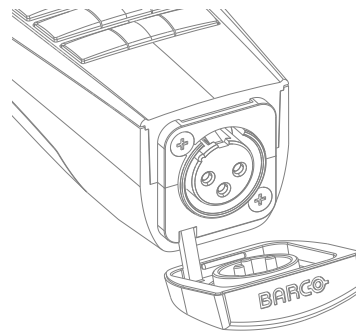

Image 5-8

2. Connect a cable with XLR plug into the XLR connector of the RCU.
3. Connect the other end of the cable with the XLR input of the projector.

5.8 Using the mini-jack connector of the RCU



Connecting a cable with the mini-jack connector will reset the broadcast address of the RCU to its default value '0'.

How to use the mini-jack connector

1. Connect a cable with the mini-jack connector (reference 2, [Image 5-9](#)) of the RCU.

2. Connect the other end of the cable with the mini-jack input of the projector.

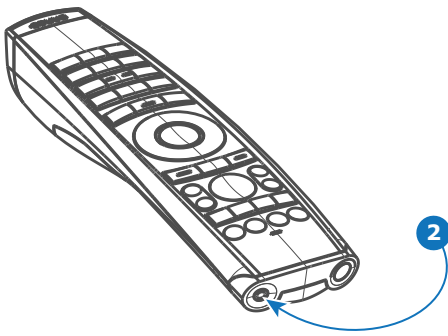

Image 5-9



Note: While the mini-jack cable is connected, the IR receivers of the projector are switched off.

5.9 Pulse RCU silicone protection sleeve (optional)

Introduction

Barco offers a silicone form fitting protection sleeve for the Pulse RCU. The silicone material keeps it comfortably, non-slip and soft to the touch. All buttons and openings remain accessible. The only thing that needs to be removed is the XLR cover.

Required tools

Scissors or knife cutter

How to install

1. Remove the XLR cover by pulling it backwards.

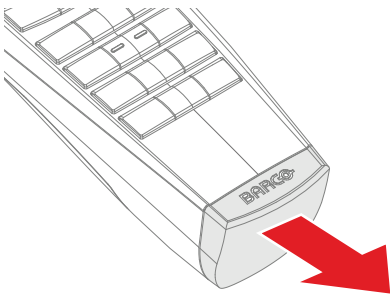

Image 5-10

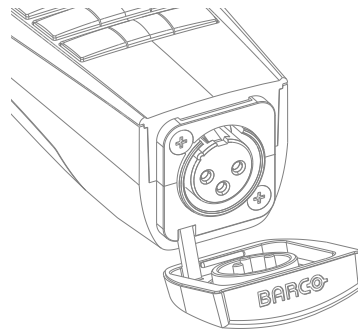

Image 5-11

2. Pull out or cut off the XLR cover. Use scissors or a knife cutter if necessary.
3. Place back side (XLR side) of the RCU into the sleeve and pull the other side of the sleeve over the front side of the RCU.

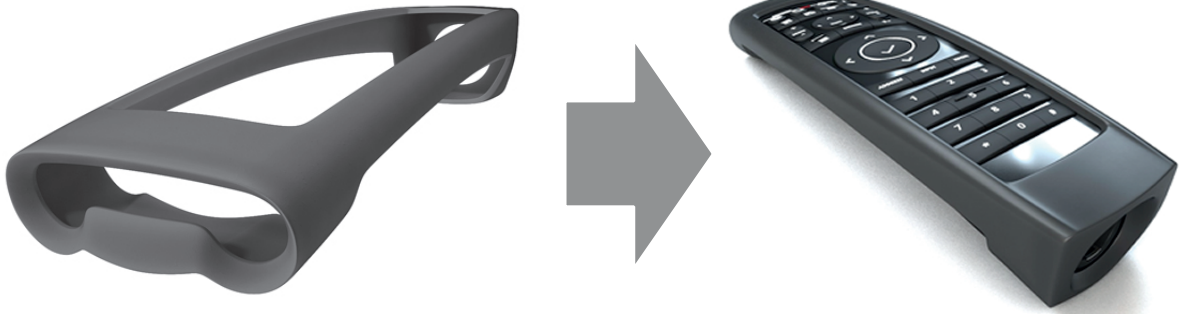

Image 5-12

6

Powering on / off

6.1	Power modes	44
6.2	Power On the projector	44
6.3	Power Off the projector	45
6.4	Power mode transitions.....	46

6.1 Power modes

Overview

The I600 has 4 different power modes:

Mode	Description
ECO STANDBY	Light source is switched off and projector electronics are powered down.
STANDBY	Light source is switched off and Control & Communication module is active.
READY	Projector is booted up and the light source is switched off.
ON	Projector is booted up and the light source is on.



Energy consumption is significantly lower in ECO STANDBY mode: only <math><0.5\text{W}</math> if network is not plugged in and 2W with network (Wake-on-LAN).



In ECO STANDBY mode, remote power up (Wake-on-LAN) and local power up (button) are supported.



Wake-On-LAN (WOL)

The link speed of the projector network interface in ECO mode is reduced to 10Mbit/s. This is standard practice in the industry to not waste power. Hence, the network connected with the projector must support such a low link speed to enable the remote wake up of the projector. This implies that all peripherals (switchers, routers...) in the network path must support WOL and configured correctly to support WOL.



Wake on DMX activity

When the projector is in STANDBY mode, DMX commands using DMX over XLR are not processed. This means that it is not possible to wake up the projector using specific "power on" DMX commands. For projectors where this is an issue, the XLR menu now has the command "Wake on DMX activity". When enabled, the projector will wake up if it detects any activity on the DMX input. When using DMX over Ethernet (using ArtNet), DMX commands are processed, even when the projector is in STANDBY mode.

6.2 Power On the projector

How to power on the projector

1. Ensure that the mains input of the projector is connected with the power net.

The projector starts up to **READY** mode as soon as the projector is connected with power net. The **Power on/off** button will blink until **Ready** mode is achieved. Once in **Ready** mode, the **Power on/off** button will be lit **WHITE**. The start up screen is displayed on the touch panel. Once the startup is completed, the status screen will be displayed.



Image 6-1

2. Press the **Power on/off** button on the projector, or the **Power On** button on the remote control.

The projector will continue to **ON** mode. The **Power on/off** button will blink until the projector is ready for projection. Once the projector is fully started up, the **Power on/off** button will be lit **BLUE**.



Image 6-2

6.3 Power Off the projector

How to power off the projector

1. While the projector is in **ON** mode, press and hold the **Standby** button on the local keypad, or the **Power Off** button on the remote control, to shut down the light source of the projector.

 **Note:** If the **auto lights source off** feature is enabled in the Power menu (see Pulse OSD user guide) the projector will automatically go to **READY** mode after a time-out if no sync is detected on the chosen source input (default 15 minutes).

The projector will switch from **ON** to **READY** mode first in order to run through a cool down phase.

2. While the projector is in **READY** mode, press and hold the **Standby** button on the local keypad, or the **Power Off** button on the remote control, to bring the projector from the **READY** mode in the **STANDBY** mode.

 **Note:** If the **auto standby** feature is enabled in the Power menu (see Pulse OSD user guide) the projector will automatically go to **STANDBY** mode after a time-out if no activity is happening on the projector (default 15 minutes).

3. While the projector is in **STANDBY** mode, press and hold the **Standby** button on the local keypad, or the **Power Off** button on the remote control, to bring the projector from the **STANDBY** mode in the **ECO STANDBY** mode.

 **Note:** If the **auto standby** feature is enabled in the Power menu (see Pulse OSD user guide) the projector will automatically go to **ECO STANDBY** mode after a time-out (default 15 minutes).



Some actions like apply a grey test pattern are done during the two minutes of the cool down phase in order to minimize the potential effect of burn-in and increase the projector lifetime.



CAUTION: Never switch off the projector by means of unplugging mains cord or by cut down of mains power.



Barco advises to keep the projector always powered and use the **ECO STANDBY** mode for low power consumption.

How to unplug the projector

1. Follow the previous power off procedure to switch off the projector.
2. Wait at least two minutes.



Caution: It is very important to wait few minutes before unplugging the power cord. If the cool down phase is not adhered, projector lifetime could be degraded.

3. Remove the power cord from the AC outlet or unplug it from the projector.

 **Note:** Some power cords have a clip that must be pressed to release the cord from the projector.

6.4 Power mode transitions

Power transition diagram

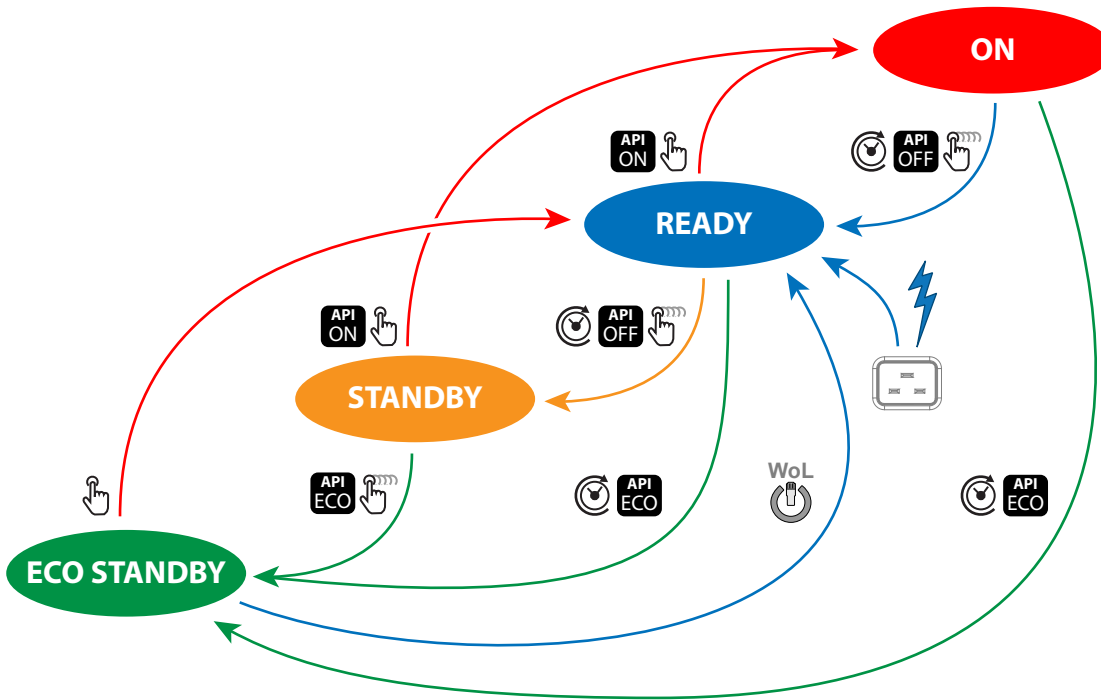

Image 6-3

Symbol	Description
	Short pressing the Power on/off button on the local keypad or on the remote control unit.
	Long pressing the Power on/off button on the local keypad or on the remote control unit.
	Wake-On-LAN (WOL). Only works if a network was connected with the LAN port of the projector while the projector went to ECO STANDBY .
	API command to change the power state of the projector (Power ON, Power OFF, Go to ECO). See Pulse user guide for more info (E.g. PJLink).
	Auto light source off and auto standby features. Default disabled (factory settings). For configuration see power saving settings in the Pulse user guide.
	The projector starts default up in READY mode when it is powered.

Wake-On-LAN (WOL)

Wake-On-LAN (WOL), the standard ethernet network command, can be used to awakened or to turn on the projector by network message.

Used alone, the WOL command allows to switch in **READY** mode. A JSON command must be performed in addition to make the projector turn in to **ON** mode:

1. Send WOL.
2. Wait for connection to façade/prospector (the unit does provide feedback when it's ready).
3. Wait for ready state.
4. Sleep 5 seconds.
5. Send JSON "power on" command (to switch in **ON** mode).

**Wake-On-LAN (WOL)**

The link speed of the projector network interface in ECO mode is reduced to 10Mbit/s. This is standard practice in the industry to not waste power. Hence, the network connected with the projector must support such a low link speed to enable the remote wake up of the projector. This implies that all peripherals (switchers, routers...) in the network path must support WOL and configured correctly to support WOL.

Inputs & Communication

7

7.1	Control & Communication module	50
7.2	Pulse HDBaseT input module	51
7.3	Pulse Quad Combo input Mk III	51
7.4	Pulse Quad DP 1.2 input	53
7.5	Pulse SFP input.....	53

7.1 Control & Communication module

Front panel Control & Communication module

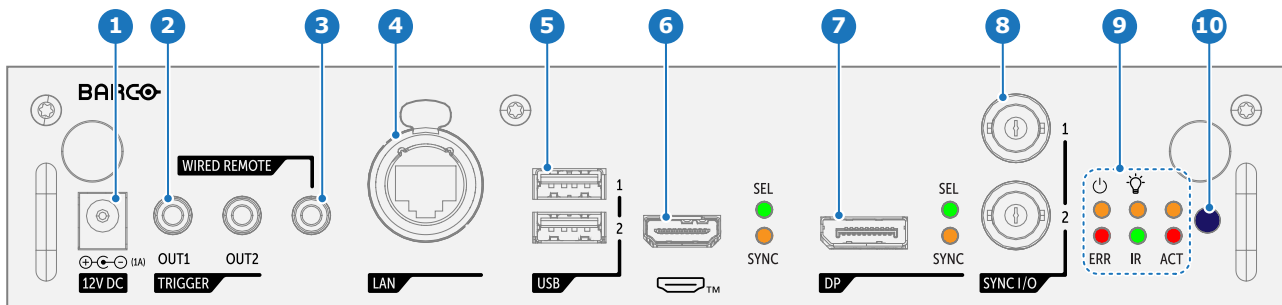

Image 7-1

- | | |
|--|---|
| <p>1 12V DC
2 TRIGGER
3 WIRED REMOTE
4 LAN
5 USB</p> | <p>6 HDMI™
7 DP
8 SYNC I/O
9 Projector status LEDs
10 IR receiver</p> |
|--|---|

Functionality

Nr	Name	Description
1	12V DC	12 V DC output, maximum 1A available when projector is not in standby.
2	TRIGGER	Two 3.5 mm mini jack connectors (OUT1 & OUT2) for controlling peripherals like motorized screens, curtains etc. Give 12V DC, 0.5A (6W) output when projector is switched on. Note: If the TRIGGER outputs are loaded too heavy, there is a risk that the projector will go in reset mode, and restart. This causes no damage to the projector, but is an undesirable response. This will also happen if the startup current for the external equipment is too high, even though the nominal power consumption is less than 0,5A
3	WIRED REMOTE	Connect the RCU via a 3.5 mm mini jack with the wired remote input to control the projector without interference.
4	LAN	Standard RJ45 connector for external projector control over IP and Art-Net. Note: Ethernet should only be connected to either the 10/100 base-T port of the Control & Communication module, or the HDBaseT input of the HDBaseT input module, or the HDBaseT input of the Quad Combo Input Mk II. Using HDBaseT inputs of different modules simultaneously will lead to undefined behavior.
5	USB	2 x USB 2.0 type A. These USB ports will simplify the service procedures for firmware updates or for downloading the log files without a network connection. The USB ports can also be used to insert the Pulse WiFi module (USB-dongle). If the only file on the USB device is the firmware file (a “*.fw” file), the projector will automatically start one of the following processes: <ul style="list-style-type: none"> • cornet<version nr>.fw: The projector will upgrade or downgrade, depending on the version number. • LogExtractor.fw: The log files will be downloaded. Note: Make sure that any used USB-stick is FAT32 compatible and contains no other files or folders.
6	HDMI™	Standard HDMI 2.1 input port for source connection to the projector.
7	DP	Standard DisplayPort™ (1.4), for source connection to the projector.
8	SYNC I/O	BNC sync port in/out for projector control. This is mainly used in multiple projector installations with requirement of synchronization between the units.
9	Status LEDs	Projector status LEDs (see chapter “ Projector status ”, page 25).
10	IR	Infra Red receiver.

LED behavior

- The SEL LED lights up GREEN: input is selected.
- The SEL LED blinks GREEN: input/output is selected and configured as output.
- The SYNC LED lights up ORANGE: valid input sync is detected.
- The SYNC LED blinks ORANGE: Sync/signal is present, but not conform with input port standard.



Non-conformity issues can be caused by older or low quality cables unable to handle the requested resolution, or connected signal converters manipulating the signal out of the supported video standards.

7.2 Pulse HDBaseT input module

Front panel Pulse HDBaseT input



Image 7-2



Ethernet should only be connected to either the 10/100 base-T port of the Control & Communication module, or the HDBaseT input of the HDBaseT input module, or the HDBaseT input of the Quad Combo Input Mk II. Using HDBaseT inputs of different modules simultaneously will lead to undefined behavior.

7.3 Pulse Quad Combo input Mk III

Front panel Quad Combo Input Mk III

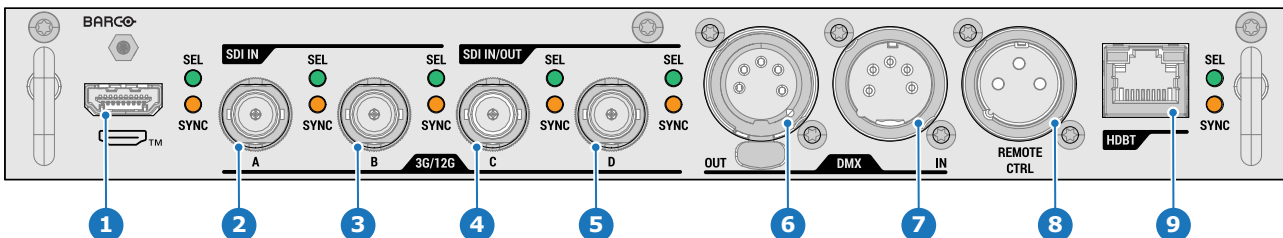

Image 7-3

- | | | | |
|---|---|---|---------------------------------|
| 1 | HDMI™ input ¹ | 6 | DMX interface input |
| 2 | Quad SDI channel A: 3G/12G input | 7 | DMX interface output |
| 3 | Quad SDI channel B: 3G/12G input | 8 | XLR for wired projector control |
| 4 | Quad SDI channel C: 3G/12G input/output | 9 | HDBaseT input |
| 5 | Quad SDI channel D: 3G/12G input/output | | |

HDMI™

Supports HDMI 2.1 features (FRL up to 4 lanes 12G)

SDI ports – How does it work?

- The **SDI port A, B, C** and **D** supports **3G/12G** input signals.
- The **SDI port C** functions as a **loop-through output** for any signal placed on **port A**.
- The **SDI port D** functions as a **loop-through output** for any signal placed on **port B**.

1. The terms HDMI, HDMI High-Definition Multimedia Interface, HDMI trade dress and the HDMI Logos are trademarks or registered trademarks of HDMI Licensing Administrator, Inc.

When connecting multiple projectors with the same signal, you can connect the signal as follows:

- Connect the source signal to Input A or B of the first projector.
- If the source signal is connected to **input A**, connect **input/output C** to the Input of the following projector.
- If the source signal is connected to **input B**, connect **input/output D** to the Input of the following projector.
- Continue in the same fashion until all projectors are connected.

DMX interface

DMX is used as communication bus between different devices in the light technic. Each device has an input and an output, so that the bus can be looped between the different devices. According the standard a five wire cable with XLR connector is used.

You can use the DMX input port to connect a DMX device (DMX console) to the projector. This way you can control the projector from that DMX device (console). The DMX output port can be connected with the next device in the loop.

DMX

Pin	Description
1	Earth
2	Cold
3	Hot
4	Return - (or not used)
5	Return + (or not used)



Due to technical reasons, the DMX interface can only be used if the Pulse Quad Combo input Mk III is mounted in input slot L1.



DMX

DMX-512 Lighting protocol over RS-485 interface. Carries information of 512 channels from a lighting controller to lighting devices. Standardized by USITT.

HDBaseT input

Supports HDBaset 3.0 (up to 4k60 RGB 444).

The HDBaseT port does not supports network connectivity.

LED behavior

- The SEL LED lights up GREEN: input is selected.
- The SEL LED blinks GREEN: input/output is selected and configured as output.
- The SYNC LED lights up ORANGE: valid input sync is detected.
- The SYNC LED blinks ORANGE: Sync/signal is present, but not conform with input port standard.



Non-conformity issues can be caused by older or low quality cables unable to handle the requested resolution, or connected signal converters manipulating the signal out of the supported video standards.



For specifications about the supported inputs for SDI, HDMI, HDBaseT and DisplayPort 1.2 see chapter "[Specifications](#)", [page 63](#).

7.4 Pulse Quad DP 1.2 input

Front panel Quad DP 1.2 input

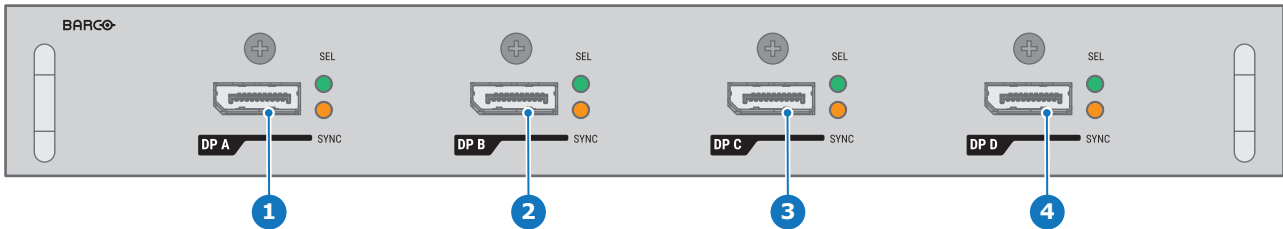

Image 7-4

- 1 Quad DisplayPort channel A input
- 2 Quad DisplayPort channel B input
- 3 Quad DisplayPort channel C input
- 4 Quad DisplayPort channel D input

LED behavior

- The SYNC LED lights up ORANGE when valid input sync is detected.
- The SEL LED lights up GREEN when the input is selected.
- Blinking YELLOW: Sync/signal is present, but not conform with input port standard.



Non-conformity issues can be caused by older or low quality cables unable to handle the requested resolution, or connected signal converters manipulating the signal out of the supported video standards.



For specifications about the supported inputs for DisplayPort 1.2 see chapter “Specifications”, page 63.

7.5 Pulse SFP input



The Barco SFP Input Board has been designed and tested to work alongside the Barco SFP Output Board.

However, it is possible that the SFP Input board can also work with other third-party devices that support 12G over fiber. Due to the many third-party options available on the market, the input board could not be tested for every option available.

Overview SFP input

The SFP Input board is used to connect 12G SDI over fiber. The SFP input is delivered without any connector. It is up to the customer to buy the necessary connectors, transceivers and cables. These parts can be mounted on the indicated places on the front panel of the board.

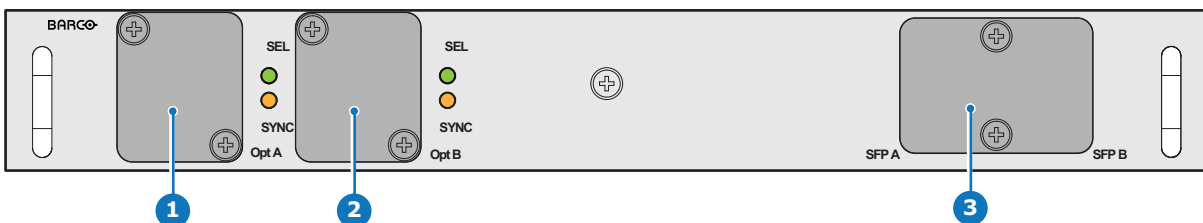

Image 7-5

- 1 Neutrik Duo optical connector or Neutrik Quad optical connector
- 2 Neutrik Duo optical connector or Neutrik Quad optical connector
- 3 2x12G SDI/10GE transceiver



For specifications about the supported inputs for SFP see chapter “Specifications”, page 63.

LED behavior

- The SYNC LED lights up ORANGE when valid input sync is detected.
- The SEL LED lights up GREEN when the input is selected.
- Blinking YELLOW: Sync/signal is present, but not conform with input port standard.



Non-conformity issues can be caused by older or low quality cables unable to handle the requested resolution, or connected signal converters manipulating the signal out of the supported video standards.

Use cases

The SFP can be configured as follows:

1. SFP+ transceiver + Fiber connection (integrated or separated)
2. Neutrik OpticalCon Duo + SFP+ transceiver + internal fiber
3. Neutrik OpticalCon Quad + SFP+ transceiver + internal fiber
4. Loop-through mode



See projector installation manual for detailed instructions on how to install/configure the SFP input.



WARNING: Only by Barco trained and qualified technicians are allowed to install the SFP input.



Optical Transceiver to comply with Laser Class 1, IEC60825–1: 2014

Dust filter

8

8.1	Replacing the dust filter.....	56
8.2	Vacuum cleaning of the dust filter foam	56
8.3	Washing and drying the dust filter foam	57

About the optional dust filter

The dust filter for the projector is an optional accessory designed to protect the internal components. This dust filter is installed on the air inlet side (front) of the projector, effectively preventing dust and other airborne particles from entering the device. By maintaining a cleaner internal environment, the front filter helps to prolong the lifespan of the projector when used in locations with high levels of dust and debris.

8.1 Replacing the dust filter

Required tools

Torx screwdriver T10

How to replace the dust filter

1. Loosen the eight screws (reference 2 [Image 8–1](#)) on the front side of the dust filter assembly (reference 1).
2. Remove the dirty dust filter assembly (reference 1) from the front cover of the projector.

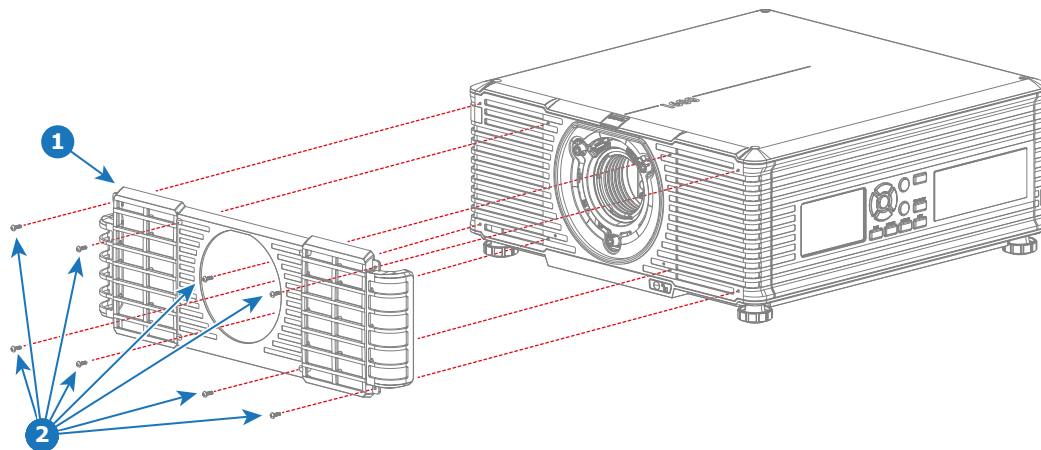

Image 8–1

3. Position the new or cleaned dust filter assembly (foam + holder) on the front cover of the projector.



Caution: Do not install a wet dust filter foam back into the projector under any circumstance. A wet filter foam can have serious safety consequences as well as jeopardize the internal optics of the system.

4. Fasten the dust filter assembly with 8 screws (reference 2 [Image 8–1](#)). Use a Torx screwdriver T10.



CAUTION: Do not install/use a damaged dust filter. Replace damaged a dust filter immediately with a new dust filter of the same type. See <https://my.barco.com> for the correct replacement part.



For cleaning instructions see “[Vacuum cleaning of the dust filter foam](#)”, page 56, or “[Washing and drying the dust filter foam](#)”, page 57.

8.2 Vacuum cleaning of the dust filter foam

When vacuum the dust filter foam

If the dust filter foam is contaminated with dust then cleaning the foam with a vacuum cleaner should be sufficient. In case the dust filter foam feels greasy then it must be washed. See cleaning procedure “[Washing and drying the dust filter foam](#)”, page 57.



Grease on the filter can build up after several months in an environment contaminated with greasy air. Note that areas where popcorn is consumed are subject to greasy air.

Prerequisites

This procedure assumes that the dust filter foam is removed from the dust filter holder. See procedure “[Replacing the dust filter](#)”, page 56.

Required tools

Vacuum cleaner with soft brush suction nozzle.

How to vacuum-clean the dust filter foam

1. Carefully vacuum the air inlet side of the dust filter foam. Use a vacuum cleaner with a soft brush suction nozzle.

 *Tip:* Lightly tap the filter foam on its dusty side to expel heavy dust contamination.

 *Tip:* Compressed air is also permitted to clean the filter foam but take care not to damage the foam.

 *Caution:* Replace a damaged dust filter foam immediately.

8.3 Washing and drying the dust filter foam

About filter foam washing and drying

For environments where popcorn grease and such can contaminate the filter foam, Barco advises the client to purchase one extra set of filter foam to cover drying time, as well as taking following extra precautions and instructions pertaining to filter foam cleaning and drying.

Cleansing agent

To clean sticky, greasy dust filter foam we suggest usage of **Sodium carbonate** crystals (Na_2CO_3). Sodium carbonate (Often called **washing soda**, **soda crystals**, or **sal soda** in the detergent section of stores) is widely used to effectively remove oil, grease, alcohol stains ... The product itself is relatively safe, sodium carbonate is used in toothpastes and as a food additive (E500). Potential Hazards are described in the section "Safety", page 9.

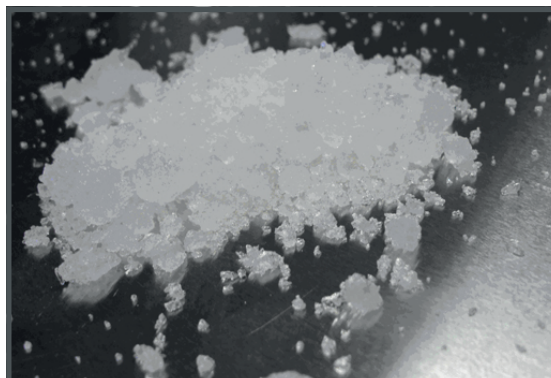

Image 8-2 Sodium carbonate crystals.



This cleaning procedure assumes that the filters are already removed from their slots.



Take into account that the time needed to dry the dust filters may be 24 hours or more. For that, it's recommended to have a second set of dust filters which can be used while cleaning the first set.

Prerequisites

This procedure assumes that the dust filter foam is removed from the dust filter holder. See procedure "Replacing the dust filter", page 56.

Required tools

- Bucket with hot water

- Sodium carbonate, 30 gram (handful) per liter hot water

How to wash and dry the dust filter foam

1. Make a solution with a ratio of 30 gram (a handful) sodium carbonate to 1 liter **hot water**.
2. Soak the dust filter foam in the solution for **30 to 60 minutes**. The grease should be dissolved after 1 hour.
3. If the dust filter is still clogged repeat this procedure from step 1.
4. Rinse the dust filters with clean water to flush all grease residue away.
5. Shake out all excess liquid by repeatedly swinging the filter to-and-fro in a centrifugal action.
6. Then allow the filters to **dry thoroughly**.



Note: Drying time of the dust filter foam can be up to 24h or more. Drying time can be shorter when being done in a well-ventilated area.



Tip: To speed-up drying, allow the filter foam to dry at 50°C max in a well ventilated room.



CAUTION: Do not install a wet dust filter foam back into the projector under any circumstance. A wet filter foam can have serious safety consequences as well as jeopardize the internal optics of the system.



CAUTION: Do not install/use a damaged dust filter. Replace damaged a dust filter immediately with a new dust filter of the same type. See <https://my.barco.com> for the correct replacement part.

Projector maintenance

9

9.1	One month maintenance actions.....	60
9.2	Software update	60
9.3	Cleaning the lens	62
9.4	Cleaning the exterior of the projector	62

9.1 One month maintenance actions

Perform every month



The monthly maintenance actions, listed below, may be performed by a trained projectionist who is familiar with potential hazards associated with the product.

No.	Maintenance action	Remarks
1	Check the surface of the lens output side for dust (it is not needed to remove the lens from the projector). Only clean if necessary.	Clean the lens output side in case dust is clearly visible upon the surface.
2	If the optional dust filter is installed, check the filter on the front air inlet of the projector.	Clean a dirty dust filter. Replace a damaged filter immediately. See procedure “Replacing the dust filter”, page 56.

9.2 Software update



CAUTION: Do not power off or unplug the projector while the software update is ongoing. Similarly, do not remove the USB flash drive while the software update is ongoing.

Prerequisites

First download the latest projector software package from the Barco's website, using the following link: <https://www.barco.com/support>.

Required tools

USB flash drive

How to update the software using Pulse Prospector

1. Ensure the projector is in Ready mode.
2. Connect to Pulse Prospector of the projector.
3. Log in as Power user or higher
4. Select *Service > Firmware > Update* in the sidebar.
5. Drag and drop the projector update file in to the dotted area in the *Firmware Update* pane.

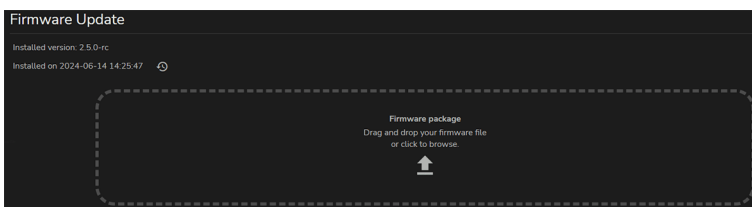

Image 9–1



Note: Do NOT turn off, power down, or remove mains power supply while the upgrade is in progress.



Note: During the firmware update, the projector will restart at some point in the process.

The firmware update process will start, and continue until finished.



For more info see the Pulse Prospector user guide.

How to update the software if the projector isn't connected to the network

1. Take a clean USB flash drive and create the following folder structure:

/Barco/Firmware



Note: Make sure the flash drive is compatible either with FAT32 or NTFS².

2. Place the correct projector update file (format .fw) in the Firmware folder.
3. Ensure the projector is in Ready mode.
4. Log in with the credentials of Power user or higher.
5. Plug the flash drive in the USB port on the Communication Panel.

A window will be prompted with the available software update packages.

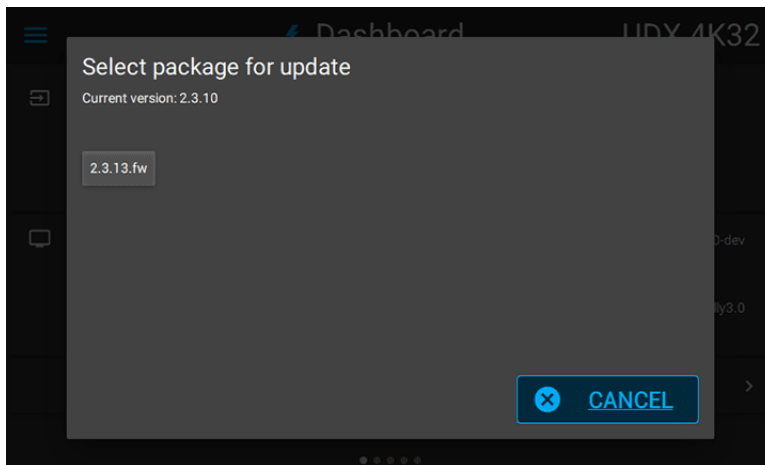

Image 9-2 Example of software packages available on the flash drive.

6. Select the desired package and confirm.

A software update dialog will be prompted, requesting confirmation.

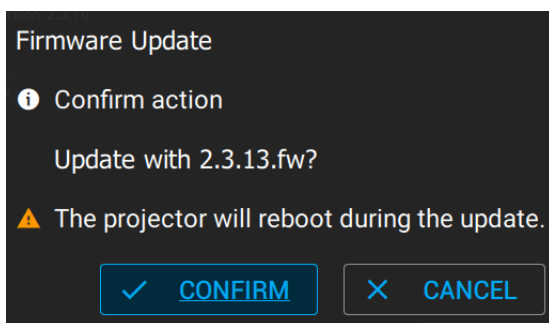

Image 9-3 Example of a Software update dialog prompt

7. Select *Confirm* to start the software update process.



Note: Once initiated, the update procedure can take up to 20 minutes to complete. During this process the projector will reboot at least once.

The LCD display will show the current status of the update during the update process.

8. Once the LCD display shows that the update process has been completed, it is safe to remove the USB flash drive.

² NTFS is only supported from Pulse 2.5 and later.



CAUTION: While it is technically possible to “downgrade” the software to an older version using this method, it is **NOT** recommended and should be avoided as much as possible. Certain features will no longer be supported, projectors can display unwanted behavior during the downgrade and in some rare cases, this may even bring damage to the device. Always contact Barco if you want to make sure a downgrade will not hurt your device.

9.3 Cleaning the lens



To minimize the possibility of damage to optical coatings, or scratches to lens surfaces follow the cleaning procedure as described here precisely.

Required tools

- Compressed air
- Clean cotton cloth
- Clean micro fiber lens cleaning cloth (e.g. Toraysee® cloth(s))
- Lens cleaner (e.g. Zeiss lens cleaner, Purosol® or any water based lens cleaner)

How to clean the lens?

1. Blow off dust with clean compressed air (or pressurized air cans³).
2. Clean with lens cleaner together with a clean lens cleaning cloth to remove the dust and contamination. Use big wipes in one single direction.



Warning: Do not wipe back and forwards across the lens surface as this tends to grind dirt into the coating.

3. Use a dry lens cleaning cloth to remove left liquid or stripes. Polish with small circles.
4. If there are still fingerprints on the surface, wipe them off with lens cleaner together with a clean lens cleaning cloth. Polish again with a dry one.



If smears occur when cleaning lenses, replace the cloth. Smears are the first indication of a dirty cloth.

9.4 Cleaning the exterior of the projector

How to clean the exterior of the projector ?

1. Switch off the projector and unplug the projector from the mains power net.
2. Clean the housing of the projector with a damp cloth. Stubborn stains may be removed with a cloth lightly dampened with a mild detergent solution.

3. Pressurized air cans are not efficient if there is too much dust on the surface, the pressure is too low

Specifications

A

A.1	I600-4K8 specifications	64
A.2	I600-4K10 specifications	65
A.3	I600-4K15 specifications	67
A.4	Specifications SDI inputs	69
A.5	Specifications HDMI inputs	70
A.6	Specifications HDBaseT input	71
A.7	Specifications DisplayPort 1.4 inputs	71
A.8	Specifications DisplayPort 1.2 inputs	72
A.9	Specifications SFP inputs	73

A.1 I600-4K8 specifications

Notes	The specifications in this document are preliminary
Projector type	4K UHD 1-chip DLP digital projector
Technology	0.8" DMD™
IR for NVG	No
Resolution	3840 x 2400 (4K UHD) 1920 x 1200 (native)
Brightness	8000 ISO lumen
Brightness uniformity	>90%
Contrast ratio	Full field 1.600:1 Barco DynaBlack® 20.000:1
Light source	Blue laser phosphor with inorganic phosphor wheel
Light source lifetime	20.000hrs
Aspect ratio	16:10 Native
Color space	REC 709
Orientation	360° rotation no restrictions
Sealed DLP™ core	Yes
24/7 operation	Yes
Processing	Pulse electronics
Color correction	P7 RealColor™
CLO (constant light output)	Yes
Keystone correction	Yes
Image processing	Embedded warp & blend
3D	Active stereoscopic 3D / Passive stereo compatible
Picture-by-picture	Two sources simultaneously *
Lens type	ILD
Optical lens shift	Vertical up to 110% depending on lens Horizontal up to 30% depending on lens
Throw Ratio	From 0.37 to 7.4
Lens range	ILD lenses - 0.37:1 / 0.5:1 / 0.65-0.8:1 / 0.8-1.0:1 / 1.0-1.4:1 / 1.4-2.1:1 / 2.1-4.0:1 / 4.0-7.4:1
Prime lenses	N/A
Inputs	HDMI™2.1 (HDCP2.2) / DP1.4 / RJ45 Ethernet / USB(5v) / 12V out / BNC 3D sync in-out
Optional Inputs	Quad DP1.2 Fiber SFP HDBaseT V3, HDCP 2.2 compatible Input Module DP1.2 HDMI™2.0 DUAL HDBaseT Quad 12G (+loop)

Input resolutions	Including and up to: WUXGA: 1920x1200@240Hz 4K UHD: 3840x2400@120Hz
Input color depth	up to 36 bpp
Software tools	Projector Toolset + Android app + iOS app + IMS
Control	IR RJ45
Network connection	10/100/1000 Mbit, Wifi (through optional dongle)
User interface	LCD touch local keypad remote control wired remote control
Web browser	Yes
Power requirements	100-240V / 15A-6A / 50-60Hz
Power consumption	640W Typical
Standby power	< 0.5W
Dissipation BTU	2150 BTU/h
Noise level (typical at 25°C/ 77°F)	40dB(A)
Operating temperature	5°-40°C / 41°-104°F (sea level)
Operating humidity	10% - 80% RH (non-condensed)
Storage temperature	-20 to 60 °C
Storage humidity	10 - 90% RH (non-condensed)
Dimensions (WxLxH)	without feet: 504x524x207mm / 19.8 x 20.6 x 8.1in
Weight	without lens: 21.5 kg / 47.4 lbs
Standard accessories	Power cord, wireless remote control
Housing	Plastic cover
Certifications	Compliant with UL: UL 62368-1, EN IEC 62368-1, and GB 4943.1; Complies with FCC rules & regulations: Part 15 Class A and CE EN55022 Class A, GB/T 9254.1 A级 and GB 17625.1; RoHS;
Warranty	Limited 3 years on parts and labor Extendable up to 5 years Service: single swap
Blend	horizontal and vertical edge blending
*	Supported when using of the optional 4x1.2 DP input board

A.2 I600-4K10 specifications

Notes	The specifications in this document are preliminary
Projector type	4K UHD 1-chip DLP digital projector
Technology	0.8" DMD™

IR for NVG	No
Resolution	3840 x 2400 (4K UHD) 1920 x 1200 (native)
Brightness	10000 ISO lumen
Brightness uniformity	>90%
Contrast ratio	Full field 1.600:1 Barco DynaBlack® 20.000:1
Light source	Blue laser phosphor with inorganic phosphor wheel
Light source lifetime	20.000hrs
Aspect ratio	16:10 Native
Color space	REC 709
Orientation	360° rotation no restrictions
Sealed DLP™ core	Yes
24/7 operation	Yes
Processing	Pulse electronics
Color correction	P7 RealColor™
CLO (constant light output)	Yes
Keystone correction	Yes
Image processing	Embedded warp & blend
3D	Active stereoscopic 3D / Passive stereo compatible
Picture-by-picture	Two sources simultaneously *
Lens type	ILD
Optical lens shift	Vertical up to 110% depending on lens Horizontal up to 30% depending on lens
Throw Ratio	From 0.37 to 7.4
Lens range	ILD lenses - 0.37:1 / 0.5:1 / 0.65-0.8:1 / 0.8-1.0:1 / 1.0-1.4:1 / 1.4-2.1:1 / 2.1-4.0:1 / 4.0-7.4:1
Prime lenses	N/A
Inputs	HDMI™2.1 (HDCP2.2) / DP1.4 / RJ45 Ethernet / USB(5v) / 12V out / BNC 3D sync in-out
Optional Inputs	Quad DP1.2 Fiber SFP HDBaseT V3, HDCP 2.2 compatible Input Module DP1.2 HDMI™2.0 DUAL HDBaseT Quad 12G (+loop)
Input resolutions	Including and up to: WUXGA: 1920x1200@240Hz 4K UHD: 3840x2400@120Hz
Input color depth	up to 36 bpp
Software tools	Projector Toolset + Android app + iOS app + IMS

Control	IR RJ45
Network connection	10/100/1000 Mbit, Wifi (through optional dongle)
User interface	LCD touch local keypad remote control wired remote control
Web browser	Yes
Power requirements	100-240V / 15A-6A / 50-60Hz
Power consumption	860W Typical
Standby power	< 0.5W
Dissipation BTU	2900 BTU/h
Noise level (typical at 25°C/ 77°F)	40dB(A)
Operating temperature	5°-40°C / 41°-104°F (sea level)
Operating humidity	10% - 80% RH (non-condensed)
Storage temperature	-20 to 60 °C
Storage humidity	10 - 90% RH (non-condensed)
Dimensions (WxLxH)	without feet: 504x524x207mm / 19.8 x 20.6 x 8.1in
Weight	without lens: 23.6 kg / 52.0 lbs
Standard accessories	Power cord, wireless remote control
Housing	Plastic cover
Certifications	Compliant with UL: UL 62368-1, EN IEC 62368-1, and GB 4943.1; Complies with FCC rules & regulations: Part 15 Class A and CE EN55022 Class A, GB/T 9254.1 A级 and GB 17625.1; RoHS;
Warranty	Limited 3 years on parts and labor Extendable up to 5 years Service: single swap
Blend	horizontal and vertical edge blending
*	Supported when using of the optional 4x1.2 DP input board

A.3 I600-4K15 specifications

Notes	The specifications in this document are preliminary
Projector type	4K UHD 1-chip DLP digital projector
Technology	0.8" DMD™
IR for NVG	No
Resolution	3840 x 2400 (4K UHD) 1920 x 1200 (native)
Brightness	14000 ISO lumen
Brightness uniformity	>90%

Contrast ratio	Full field 1.600:1 Barco DynaBlack® 20.000:1
Light source	Blue laser phosphor with inorganic phosphor wheel
Light source lifetime	20.000hrs
Aspect ratio	16:10 Native
Color space	REC 709
Orientation	360° rotation no restrictions
Sealed DLP™ core	Yes
24/7 operation	Yes
Processing	Pulse electronics
Color correction	P7 RealColor™
CLO (constant light output)	Yes
Keystone correction	Yes
Image processing	Embedded warp & blend
3D	Active stereoscopic 3D / Passive stereo compatible
Picture-by-picture	Two sources simultaneously *
Lens type	ILD
Optical lens shift	Vertical up to 110% depending on lens Horizontal up to 30% depending on lens
Throw Ratio	From 0.37 to 7.4
Lens range	ILD lenses - 0.37:1 / 0.5:1 / 0.65-0.8:1 / 0.8-1.0:1 / 1.0-1.4:1 / 1.4-2.1:1 / 2.1-4.0:1 / 4.0-7.4:1
Prime lenses	N/A
Inputs	HDMI™2.1 (HDCP2.2) / DP1.4 / RJ45 Ethernet / USB(5v) / 12V out / BNC 3D sync in-out
Optional Inputs	Quad DP1.2 Fiber SFP HDBaseT V3, HDCP 2.2 compatible Input Module DP1.2 HDMI™2.0 DUAL HDBaseT Quad 12G (+loop)
Input resolutions	Including and up to: WUXGA: 1920x1200@240Hz 4K UHD: 3840x2400@120Hz
Input color depth	up to 36 bpp
Software tools	Projector Toolset + Android app + iOS app + IMS
Control	IR RJ45
Network connection	10/100/1000 Mbit, Wifi (through optional dongle)
User interface	LCD touch local keypad remote control wired remote control
Web browser	Yes
Power requirements	100-240V / 15A-6A / 50-60Hz

Power consumption	1200W Typical
Standby power	< 0.5W
Dissipation BTU	4095 BTU/h
Noise Level	40dB(A)
Operating temperature	5°-40°C / 41°-104°F (sea level)
Operating humidity	10% - 80% RH (non-condensed)
Storage temperature	-20 to 60 °C
Storage humidity	10 - 90% RH (non-condensed)
Dimensions (WxLxH)	without feet: 504x524x207mm / 19.8 x 20.6 x 8.1in
Weight	without lens: 23.7 kg / 52.3 lbs
Standard accessories	Power cord, wireless remote control
Housing	Plastic cover
Certifications	Compliant with UL: UL 62368-1, EN IEC 62368-1, and GB 4943.1; Complies with FCC rules & regulations: Part 15 Class A and CE EN55022 Class A, GB/T 9254.1 A级 and GB 17625.1; RoHS;
Warranty	Limited 3 years on parts and labor Extendable up to 5 years Service: single swap
Blend	horizontal and vertical edge blending
*	Supported when using of the optional 4x1.2 DP input board

A.4 Specifications SDI inputs



HD-SDI follows the SMPTE 292M standard.
3G SDI follows the SMPTE 425M standard Level A.
12G-SDI follows the SMPTE ST-2082-1 and ST-2082-10 standards.

SDI specifications

Specification	Value		
Color space	YCbCr		
Color depth	10 bpc		
Chroma sampling	4:2:2		
Audio	not supported		
3D	not supported		
Video timings progressive	Type	Port type	Format
	HD-SDI	Single link Quad link	<ul style="list-style-type: none"> • 1920 x 1080 @24 Hz • 1920 x 1080 @25 Hz • 1920 x 1080 @30 Hz • 1280 x 720 @50 Hz • 1280 x 720 @60 Hz

Specification	Value		
	3G-SDI Level A	Single link Quad link	<ul style="list-style-type: none"> • 1920 x 1080 @50 Hz and @60 Hz • 2048 x 1080 @50 Hz and @60 Hz
	3G-SDI "Barco Link"	Single link Quad link	1920 x 1200 @50 Hz, @59.94 Hz and @60 Hz
	12G-SDI	Single link	3840 x 2160 @50 Hz and @60 Hz 4096 x 2160 @50 Hz and @60 Hz
	12G-SDI "BarcoLink 4k"	Single link	3840 x 2400 @50 Hz, @59.94 Hz and @60 Hz.

A.5 Specifications HDMI inputs

HDMI specifications

The HDMI inputs support the following HDMI 2.1 features:

Specification	Value
Pixel rate	25 – 1188 MHz pixel clock
HDCP support	<ul style="list-style-type: none"> • HDCP 1.4 • HDCP 2.x
Color space	<ul style="list-style-type: none"> • YCbCr 4:2:0 • YCbCr 4:2:2 • YCbCr 4:4:4 • RGB 4:4:4
Color depth	<ul style="list-style-type: none"> • 24 bpp • 30 bpp • 36 bpp
3D support	<ul style="list-style-type: none"> • Field sequential 3D (Active 3D) <ul style="list-style-type: none"> - Frame-packed - Top Bottom progressive - Side-by-side progressive • Passive 3D not supported.
Audio	Not supported
Video timings progressive	<ul style="list-style-type: none"> • 640 x 480 @60 Hz • 720 x 480 @60 Hz • 720 x 576 @50 Hz • 1280 x 720 @50 Hz and @60 Hz • 1920 x 1080 up to and including @60 Hz • 3840 x 2160 up to and including @120 Hz • 4096 x 2160 up to and including @120 Hz
Video timings interlaced	<ul style="list-style-type: none"> • 1920 x 1080 @50 Hz • 1920 x 1080 @60 Hz

A.6 Specifications HDBaseT input

HDBaseT specifications

Specification	Value
Pixel rate	25 – 594 MHz pixel clock
Color space	<ul style="list-style-type: none"> • YCbCr 4:2:0 • YCbCr 4:2:2 • YCbCr 4:4:4 • RGB 4:4:4
Color depth	<ul style="list-style-type: none"> • 24 bpp • 30 bpp • 36 bpp
HDCP support	<ul style="list-style-type: none"> • HDCP 1.x • HDCP 2.2
Network support	No longer supported
For future release	<ul style="list-style-type: none"> • 3D support
Not supported	<ul style="list-style-type: none"> • Audio • Power over HDBaseT
Video timings	<ul style="list-style-type: none"> • 4096 x 2160 up to and including @60 Hz • 2048 x 1080 up to and including @120 Hz • 1920 x 1080 up to and including @120 Hz



CAUTION: The HDBaseT inputs can bridge a distance of 100 m but are sensitive to radiated electromagnetic interference: radiated electromagnetic interference (e.g. from GSM or switching inductive or capacitive loads) within the limits of electromagnetic compatibility requirements of 3 V/m can cause random flashes or temporary loss of the projected image. As such, shielded CAT-6a cables (or higher) with metal RJ-45 connectors are recommended; choose cable length no longer than required and route HDBT cable optimally screened from possible sources of electromagnetic emission.

A.7 Specifications DisplayPort 1.4 inputs

DisplayPort 1.4 specifications

Pixel rate	Up to 1080 MHz pixel clock
Color format support	<ul style="list-style-type: none"> • RGB • YCbCr 4:2:2 • YCbCr 4:4:4
Color depth support	<ul style="list-style-type: none"> • 18 bpp • 24 bpp • 30 bpp • 36 bpp
Data rate support	<ul style="list-style-type: none"> • 1.62 Gbps: Reduced Bit Rate (RBR) • 2.7 Gbps: High Bit Rate (HBR) • 5.4 Gbps: High Bit Rate 2 (HBR2) • 8.1 Gbps: High Bit Rate 3 (HBR3)
HDCP support	<ul style="list-style-type: none"> • HDCP 1.3 • HDCP 2.x
Audio	not supported

3D support	<ul style="list-style-type: none"> Field sequential 3D (Active 3D) Passive stereoscopic 3D (Passive stereo) converted to active 3D
Video timings	<ul style="list-style-type: none"> 1920 x 1080 @60 Hz and @120 Hz 1920 x 1200 @60 Hz and @120 Hz 1920 x 2160 @60 Hz and @120 Hz 2560 x 1600 @24 Hz, @60 Hz and @120 Hz 3840 x 2160 @24 Hz, @50 Hz and @60 Hz 3840 x 2400 @24 Hz, @50 Hz and @60 Hz 4096 x 2176 @60 Hz 960 x 2160 @60 Hz and @120 Hz

 **CAUTION:** In order to display high resolution images (e.g.: 3840 x 2160 @60 Hz or higher) via the DisplayPort input, the quality of the cable must be adequate, in addition the length of the cable can also influence the performance (recommended maximum ~1 meter for DP 1.4 and ~1.2 meter for DP 1.2);. In case there is an issue with one of these criteria the automatic link-training initiated by the DP-standard may decide to switch to a lower resolution.

A.8 Specifications DisplayPort 1.2 inputs

DisplayPort 1.2 specifications

Pixel rate	Up to 600 MHz pixel clock		
Color space	<ul style="list-style-type: none"> YCbCr 4:2:2 YCbCr 4:4:4 RGB 4:4:4 		
Color depth	<ul style="list-style-type: none"> 24 bpp 30 bpp 36 bpp 		
Data rate support	<ul style="list-style-type: none"> 1.62 Gbps: Reduced Bit Rate (RBR) 2.7 Gbps: High Bit Rate (HBR) 5.4 Gbps: High Bit Rate 2 (HBR2) 		
For future release	<ul style="list-style-type: none"> Interlaced support HDCP 1.4 		
Audio	not supported		
3D support	<ul style="list-style-type: none"> Field sequential 3D (Active 3D) Passive stereoscopic 3D (Passive stereo) converted to active 3D 		
Video timings progressive	2D / 3D	Layout Mode⁴	Supported formats
	2D	Standard layout (1x1 layout)	<ul style="list-style-type: none"> 1920 x 1080 @60 Hz and @120 Hz 1920 x 1200 @60 Hz and @120 Hz 1920 x 2160 @60 Hz and @120 Hz 2560 x 1600 @24 Hz, @60 Hz and @120 Hz 3840 x 2160 @24 Hz, @50 Hz and @60 Hz 3840 x 2400 @24 Hz, @50 Hz and @60 Hz 960 x 2160 @60 Hz and @120 Hz
	2D	2 column mode (2x1 layout)	<ul style="list-style-type: none"> 1920 x 2160 @60 Hz and @120 Hz 1920 x 2400 @60 Hz

4. Only 1x1 layout is supported on the Quad Combo input boards. The Quad DP1.2 input supports all layout configurations.

			<ul style="list-style-type: none"> • 2048 x 2160 @60 Hz and @120 Hz
	2D	4 quadrant mode (2x2 layout)	<ul style="list-style-type: none"> • 960 x 1080 @120 Hz • 960 x 1200 @120 Hz • 1280 x 1080 @60 Hz and @120 Hz • 1280 x 1600 @60 Hz and @120 Hz • 1920 x 1080 @120 Hz • 1920 x 1200 @120 Hz • 2048 x 1080 @120 Hz
	2D	4 column mode (4x1 layout)	<ul style="list-style-type: none"> • 960 x 2160 @120 Hz • 960 x 2400 @120 Hz • 1024 x 2160 @60 Hz
	Active 3D	Standard layout (1x1 layout)	<ul style="list-style-type: none"> • 1600 x 1200 @120 Hz • 2560 x 1080 @120 Hz • 2560 x 1600 @120 Hz
	Active 3D	2 column mode (2x1 layout)	1920 x 2160 @120 Hz
	Active 3D	4 quadrant mode (2x2 layout)	<ul style="list-style-type: none"> • 1920 x 1080 @120 Hz • 1920 x 1200 @120 Hz • 2048 x 1080 @120 Hz
	Active 3D	4 column mode (4x1 layout)	<ul style="list-style-type: none"> • 960 x 2160 @120 Hz • 960 x 2400 @120 Hz • 1024 x 2160 @120 Hz
	Passive stereo	Standard layout (1x1 layout)	3840 x 2160 @60 Hz
	Passive stereo	2 column mode (2x1 layout)	1920 x 2160 @60 Hz



CAUTION: In order to display high resolution images (e.g.: 3840 x 2160 @60 Hz) via the DP1.2 input, the quality of the cable must be adequate, in addition the length of the cable can also influence the performance. In case there is an issue with one of these criteria the automatic link-training initiated by the DP-standard may decide to switch to a lower resolution.

A.9 Specifications SFP inputs

SFP specifications

Color space	YCbCr		
Color depth	10 bpc		
Chroma sampling	4:2:2		
Audio support	not supported		
Video timings progressive	Type	Port type	Format
	HD-SDI	Single link	<ul style="list-style-type: none"> • 1920 x 1080 up to and including @30 Hz • 1280 x 720 up to and including @60 Hz
	3G-SDI	Single link	1920 x 1080 @50 Hz and @60 Hz 1920 x 1200 @50 Hz, @59.94 Hz and @60 Hz. 2048 x 1080 @50 Hz and @60 Hz

	12G-SDI	Single link	3840 x 2160 @50 Hz and @60 Hz 4096 x 2160 @50 Hz and @60 Hz 3840 x 2400 @50 Hz, @59.94 and @60 Hz
--	---------	-------------	---

DMX chart

B

B.1	DMX chart input module position.....	76
B.2	DMX chart, Basic.....	76
B.3	DMX chart, Extended.....	77

B.1 DMX chart input module position

About the input boards

The projectors have a Control and Communication panel, as well as up to two input slots (amount depends on model). These input slots are marked internally as “L1” and “L2”.

The input selection commands in the basic DMX chart only applies to the input module in slot L1.

The input selection commands in the extended DMX chart are as follows:

- Use channel 2 to target the input module located in slot L1
- Use channel 14 to target the input module located in slot L2 (if available).

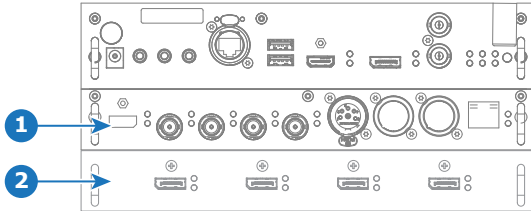

Image B-1

- 1 Slot L1, here filled with the Quad combo Input MKIII module
- 2 Slot L2, here filled with the Quad DP 1.2 Input module

B.2 DMX chart, Basic

Overview

Ch.	Function	Value	Default	Action
1	Shutter + Intensity	0 - 7	255	Close shutter
		8 - 255		Adjust intensity
2	Profile selection + Input selection on input board installed in slot L1	0 - 7	0	No function
		8 - 15		Activate first profile preset (If held for 1 second)
		16 - 23		Activate second profile preset (If held for 1 second)
		24 - 31		Activate third profile preset (If held for 1 second)
		32 - 39		Activate fourth profile preset (If held for 1 second)
		40 - 47		Activate fifth profile preset (If held for 1 second)
		48 - 55		Activate sixth profile preset (If held for 1 second)
		56 - 63		Activate seventh profile preset (If held for 1 second)
		64 - 71		Activate eighth profile preset (If held for 1 second)
		72 - 79		Activate ninth profile preset (If held for 1 second)
		80 - 87		Activate tenth profile preset (If held for 1 second)
		88 - 95		Select HDMI input on the Control and Communication module (If held for 1 second)
		96 - 103		Select DisplayPort input on the Control and Communication module (If held for 1 second)
		104 - 111		Select HDMI input on Quad Combo MKIII (If held for 1 second)
112 - 119	Select SDI Input A on Quad Combo MKIII (If held for 1 second)			
120 - 127	Select SDI Input B on Quad Combo MKIII (If held for 1 second)			

Ch.	Function	Value	Default	Action
		128 - 135		Select SDI Input C on Quad Combo MKIII (If held for 1 second)
		136 - 143		Select SDI Input D on Quad Combo MKIII (If held for 1 second)
		144 - 151		Select Quad SDI on Quad Combo MKIII (If held for 1 second)
		152 - 159		Select HDBaseT input on Quad Combo MKIII if installed in slot L1 (If held for 1 second)
		160 - 167		Select DisplayPort Input A on Quad DP if installed in slot L1 (If held for 1 second)
		168 - 175		Select DisplayPort Input B on Quad DP if installed in slot L1 (If held for 1 second)
		176 - 183		Select DisplayPort Input C on Quad DP if installed in slot L1 (If held for 1 second)
		184 - 191		Select DisplayPort Input D on Quad DP if installed in slot L1 (If held for 1 second)
		192 - 199		Select Dual DisplayPort AB on Quad DP if installed in slot L1 (If held for 1 second)
		200 - 207		Select Quad column DisplayPort on Quad DP if installed in slot L1 (If held for 1 second)
		208 - 215		Power on / Light source on (If held for 5 seconds)
		216 - 223		Power down / Light source off (if held for 5 seconds)
		224 - 255		Reserved for future functionality

B.3 DMX chart, Extended

Overview

Ch.	Function	Value	Default	Actions
1	Shutter + Intensity	0 - 7	255	Close shutter
		8 - 255		Adjust intensity
2	Brightness	0 - 255	128	Adjusts the brightness between 0 and 100% on input.
3	Contrast	0 - 255	128	Adjusts the contrast between 0 and 100% on input
4	Profile selection + Input selection on input board installed in slot L1	0 - 7	0	No function
		8 - 15		Activate first profile preset (If held for 1 second)
		16 - 23		Activate second profile preset (If held for 1 second)
		24 - 31		Activate third profile preset (If held for 1 second)
		32 - 39		Activate fourth profile preset (If held for 1 second)
		40 - 47		Activate fifth profile preset (If held for 1 second)
		48 - 55		Activate sixth profile preset (If held for 1 second)
		56 - 63		Activate seventh profile preset (If held for 1 second)
		64 - 71		Activate eighth profile preset (If held for 1 second)
		72 - 79		Activate ninth profile preset (If held for 1 second)
		80 - 87		Activate tenth profile preset (If held for 1 second)
88 - 95	Select HDMI input on the Control and Communication module (If held for 1 second)			

Ch.	Function	Value	Default	Actions
		96 - 103		Select DisplayPort input on the Control and Communication module (If held for 1 second)
		104 - 111		Select HDMI input on Quad Combo MKIII if installed in slot L1 (If held for 1 second)
		112 - 119		Select SDI Input A on Quad Combo MKIII if installed in slot L1 (If held for 1 second)
		120 - 127		Select SDI Input B on Quad Combo MKIII if installed in slot L1 (If held for 1 second)
		128 - 135		Select SDI Input C on Quad Combo MKIII if installed in slot L1 (If held for 1 second)
		136 - 143		Select SDI Input D on Quad Combo MKIII if installed in slot L1 (If held for 1 second)
		144 - 151		Select Quad SDI on Quad Combo MKIII if installed in slot L1 (If held for 1 second)
		152 - 159		Select HDBaseT input on Quad Combo MKIII if installed in slot L1 (If held for 1 second)
		160 - 167		Select DisplayPort Input A on Quad DP if installed in slot L1 (If held for 1 second)
		168 - 175		Select DisplayPort Input B on Quad DP if installed in slot L1 (If held for 1 second)
		176 - 183		Select DisplayPort Input C on Quad DP if installed in slot L1 (If held for 1 second)
		184 - 191		Select DisplayPort Input D on Quad DP if installed in slot L1 (If held for 1 second)
		192 - 199		Select Dual DisplayPort AB on Quad DP if installed in slot L1 (If held for 1 second)
		200 - 207		Select Quad column DisplayPort on Quad DP if installed in slot L1 (If held for 1 second)
		208 - 215		Select Quad DisplayPort on Quad DP if installed in slot L1 (If held for 1 second)
		216 - 223		Select Fiber input A if Pulse SFP is installed in slot L1
		224 - 231		Select Fiber input B if Pulse SFP is installed in slot L1
		232 - 255		Reserved for future functionality
5	Focus (MSB)	0 - 255	128	Set coarse lens focus adjustment ⁵
6	Focus (LSB)	0 - 255	128	Set fine lens focus adjustment ⁵
7	Zoom (MSB)	0 - 255	128	Set coarse lens zoom adjustment ⁵
8	Zoom (LSB)	0 - 255	128	Set fine lens zoom adjustment ⁵
9	Lens shift vertical (MSB)	0 - 255	128	Set coarse lens shift in vertical direction
10	Lens shift vertical (LSB)	0 - 255	128	Set fine lens shift in vertical direction
11	Lens shift horizontal (MSB)	0 - 255	128	Set coarse lens shift in horizontal direction
12	Lens shift horizontal (LSB)	0 - 255	128	Set fine lens shift in horizontal direction

5. Only when lens has been calibrated

Ch.	Function	Value	Default	Actions
13	Light Source Power ⁶	0	0	Set light source to 100%
		1 - 61		Set light source to value From 100% to 40% in 1% reductions (e.g. 11 is 90%, 26 is 75%, etc)
		64		Set light source to 35%
		67		Set light source to 30%
		70		Set light source to 25%
		73		Set light source to 20%
		76		Set light source to 15%
		79		Set light source to 10%
		80 - 87		Power on / Light source on (If held for 5 seconds)
		88- 95		Power down / Light source off (if held for 5 seconds)
		96 - 255		Reserved for future functionality
14	Calibration + Input selection on input board installed in slot L2 (if available)	0 - 7	0	No functionality
		8 - 15		Calibrate lens zoom & focus (if held for 5 seconds)
		16 - 23		Calibrate lens horizontal and vertical shift (if held for 5 seconds)
		24 - 31		Calibrate lens (zoom, focus and shift) (if held for 5 seconds)
		32 - 103		Reserved for future functionality
		104 - 111		Select HDMI input on Quad Combo MKIII if installed in slot L2 (If held for 1 second)
		112 - 119		Select SDI Input A on Quad Combo MKIII if installed in slot L2 (If held for 1 second)
		120 - 127		Select SDI Input B on Quad Combo MKIII if installed in slot L2 (If held for 1 second)
		128 - 135		Select SDI Input C on Quad Combo MKIII if installed in slot L2 (If held for 1 second)
		136 - 143		Select SDI Input D on Quad Combo MKIII if installed in slot L2 (If held for 1 second)
		144 - 151		Select Quad SDI on Quad Combo MKIII if installed in slot L2 (If held for 1 second)
		152 - 159		Select HDBaseT input on Quad Combo MKIII if installed in slot L2 (If held for 1 second)
		160 - 167		Select DisplayPort Input A on Quad DP if installed in slot L2 (If held for 1 second)
		168 - 175		Select DisplayPort Input B on Quad DP if installed in slot L2 (If held for 1 second)
		176 - 183		Select DisplayPort Input C on Quad DP if installed in slot L2 (If held for 1 second)
		184 - 191		Select DisplayPort Input D on Quad DP if installed in slot L2 (If held for 1 second)
		192 - 199		Select Dual DisplayPort AB on Quad DP if installed in slot L2 (If held for 1 second)
200 - 207	Select Quad column DisplayPort on Quad DP if installed in slot L2 (If held for 1 second)			

6. If the Light Source is forced to an output below its minimum value, it will remain at its minimum output value

Ch.	Function	Value	Default	Actions
		208 - 215		Select Quad DisplayPort on Quad DP if installed in slot L2 (If held for 1 second)
		216 - 223		Select Fiber input A if Pulse SFP is installed in slot L2
		224 - 231		Select Fiber input B if Pulse SFP is installed in slot L2
		232 - 255		Reserved for future functionality

Dimensions

C

C.1	Projector outer dimensions	82
C.2	Mounting holes bottom plate	83

C.1 Projector outer dimensions

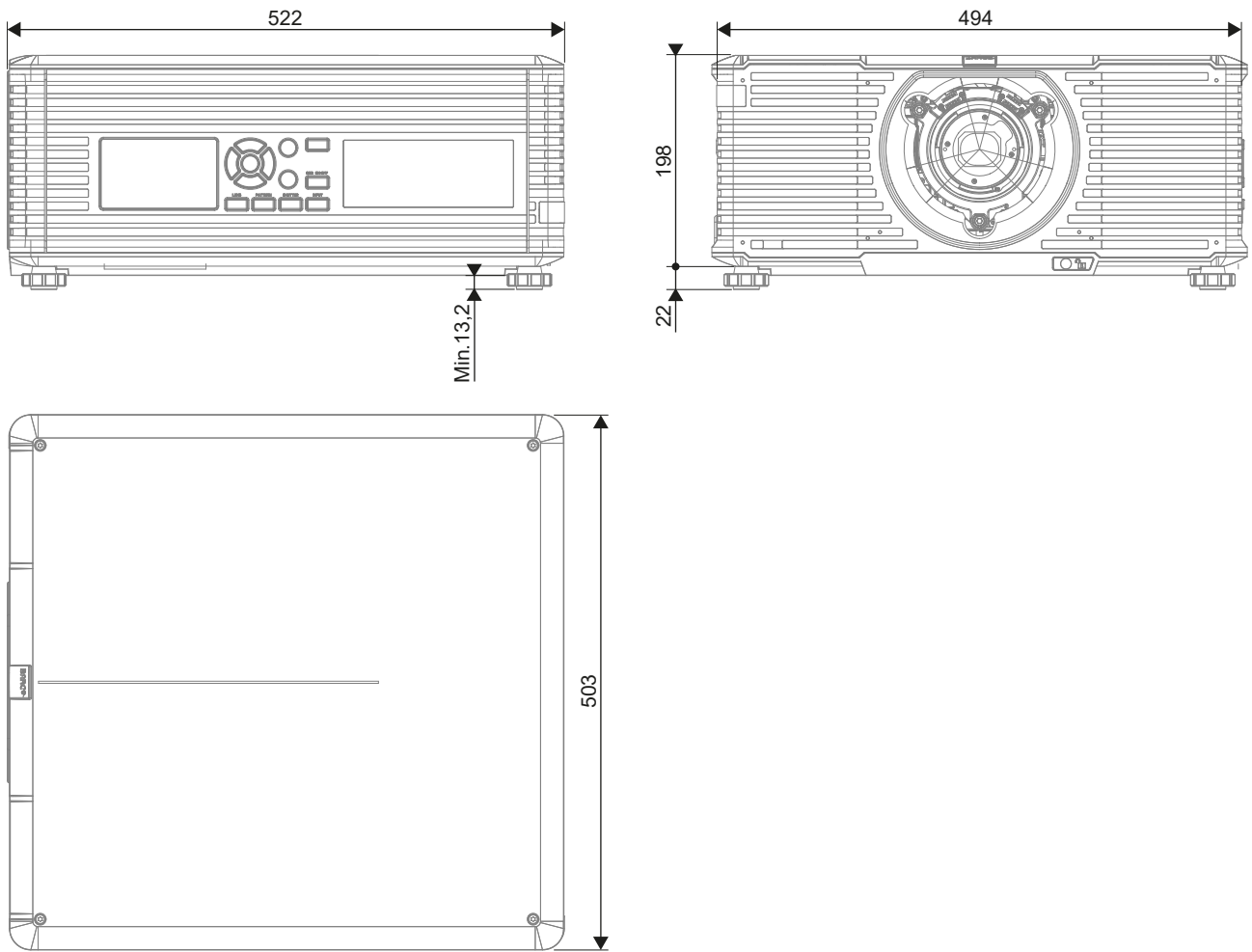

Image C-1 All dimensions given in mm.

C.2 Mounting holes bottom plate

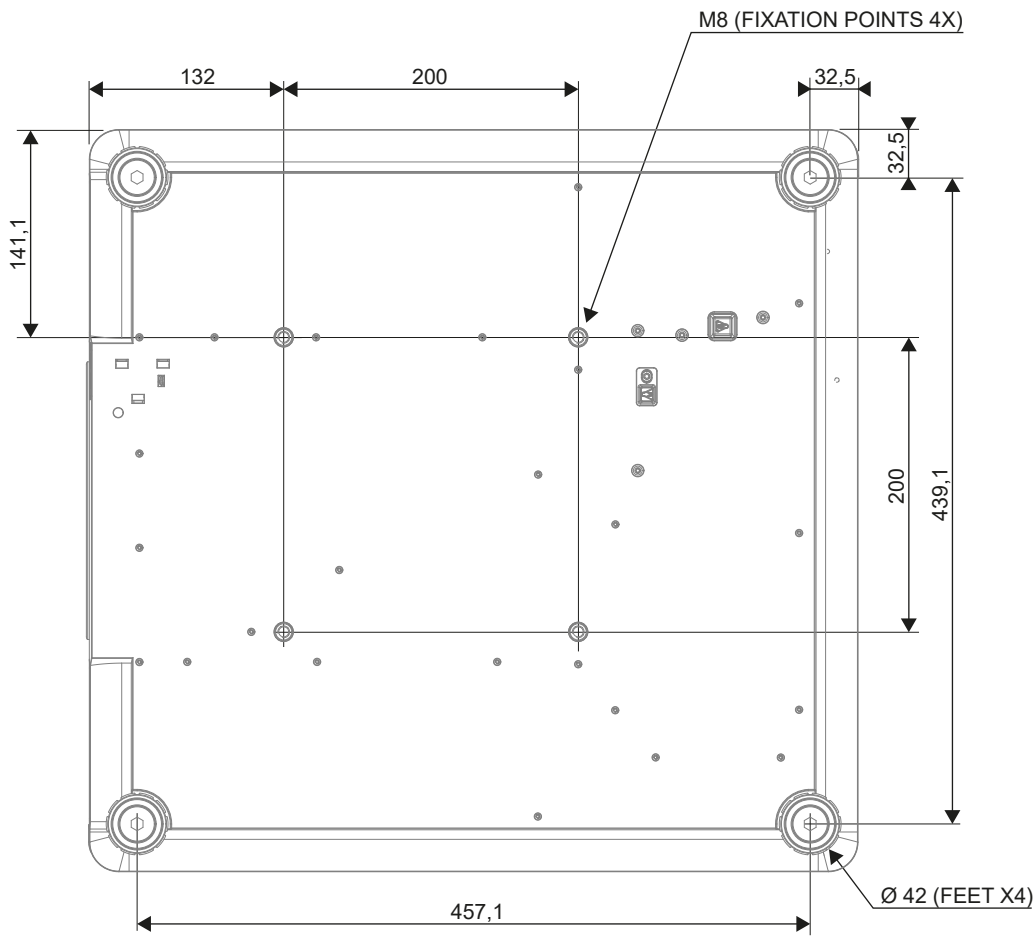

Image C-2 All dimensions given in mm.

Regulatory

D

D.1	Contact information.....	86
D.2	Production information	86
D.3	Product compliance EU.....	86
D.4	Product compliance UK.....	87
D.5	Product compliance US.....	87
D.6	Product compliance Turkey	87
D.7	Product compliance EAC	88
D.8	Product compliance China.....	88
D.9	Product compliance Taiwan	89
D.10	Trademark notice.....	91
D.11	Product privacy statement	91

D.1 Contact information

Contact address

Barco NV

Beneluxpark 21, 8500 Kortrijk, Belgium

www.barco.com

Importers contact information

To find your local importer, contact Barco directly or one of Barco's regional offices via the contact information given on Barco's web site, <https://www.barco.com>.

Manufacturer

Manufacturer: Barco (Wuxi) Technology Co., Ltd.

No. 38, Chunhui Middle Road, XiShan District, 214101 Wuxi CHINA

合法制造商: 巴可 (无锡) 科技有限公司

中国无锡市锡山区春晖中路38号, 邮编214101

D.2 Production information

Made in information

The made in country is indicated on the product ID label on the product itself.

Production date

The month and year of production is indicated on the product ID label on the product itself.

Factory address

Factory: Barco (Wuxi) Technology Co., Ltd.

No. 38, Chunhui Middle Road, XiShan District, 214101 Wuxi CHINA

工厂: 巴可 (无锡) 技有限公司

中国无锡市锡山区春晖中路38号, 邮编214101

D.3 Product compliance EU

Disposal Information



Waste Electrical and Electronic Equipment (WEEE)

This symbol on the product indicates that, under the European Directive 2012/19/EU governing waste from electrical and electronic equipment, this product must not be disposed of with other municipal waste. Please dispose of your waste equipment by handing it over to a designated collection point for the recycling of waste electrical and electronic equipment. To prevent possible harm to the environment or human health from uncontrolled waste disposal, please separate these items from other types of waste and recycle them responsibly to promote the sustainable reuse of material resources.

For more information about recycling of this product, please contact your local city office or your municipal waste disposal service. For details, please visit the Barco website at: <https://www.barco.com/about/sustainability/waste-of-electronic-equipment-customers>

Disposal of batteries in the product



This product contains batteries covered by the Directive 2006/66/EC which must be collected and disposed of separately from municipal waste.

If the battery contains more than the specified values of lead (Pb), mercury (Hg) or cadmium (Cd), these chemical symbols will appear below the crossed-out wheeled bin symbol.

By participating in separate collection of batteries, you will help to ensure proper disposal and to prevent potential negative effects on the environment and human health.

EMC notices Europe

EN55032/CISPR32 Class A MME (MultiMedia Equipment)

Warning : This equipment is compliant with Class A of CISPR 32. In a residential environment this equipment may cause radio interference.

D.4 Product compliance UK

UK Compliance



This product is fit for use in the UK.

Authorised Representative: Barco UK Ltd

Address: Building 329, Doncastle Road
Bracknell RG12 8PE, Berkshire, United Kingdom

D.5 Product compliance US

Federal Communications Commission (FCC Statement)

This equipment has been tested and found to comply with the limits for a class A digital device, pursuant to Part 15 of the FCC rules. These limits are designed to provide reasonable protection against harmful interference when the equipment is operated in a commercial environment. This equipment generates, uses, and can radiate radio frequency energy and, if not installed and used in accordance with the instruction manual, may cause harmful interference to radio communications. Operation of this equipment in a residential area may cause harmful interference, in which case the user will be responsible for correcting any interference at his own expense

Changes or modifications not expressly approved by the party responsible for compliance could void the user's authority to operate the equipment

FCC responsible: Barco Inc.
3059 Premiere Parkway Suite 400
30097 Duluth GA, United States
Tel: +1 678 475 8000

D.6 Product compliance Turkey

Turkey RoHS compliance



Türkiye Cumhuriyeti: AEEE Yönetmeliğine Uygundur.
[Republic of Turkey: In conformity with the WEEE Regulation]

D.7 Product compliance EAC

EurAsian Conformity (EAC)



This product complies with the Safety of Low-Voltage Equipment (LVE Technical Regulation 004/2011, CU TR 004/2011) and the Electromagnetic Compatibility of Technical Products (EMC Technical regulation, CU TR 020/2011) and Restriction of use of Hazardous Substances in radio and electronic devices (RoHS Technical regulation, CU TR 037/2016).

D.8 Product compliance China

EMC notices China

GB/T 9254.1 A级ITE(信息技术设备)

警告：在居住环境中，运行此设备可能会造成无线电干扰。

产品中有害物质的名称及含有信息表 (China RoHS compliance)

根据中华人民共和国《电器电子产品有害物质限制使用管理办法》规定，以下部分列出了Barco产品中可能包含的有毒和/或有害物质的名称和含量。

部件名称 Component name	有害物质 Hazardous Substances or Elements									
	铅 (Pb)	汞 (Hg)	镉 (Cd)	六价铬 (Cr ⁶⁺)	多溴联苯 (PBB)	多溴二苯醚 (PBDE)	邻苯二甲酸二正丁酯 (DBP)	邻苯二甲酸二异丁酯 (DIBP)	邻苯二甲酸丁基苄酯 (BBP)	邻苯二甲酸二(2-乙基)己酯 (DEHP)
印制电路配件 Printed Circuit Assemblies	X	○	○	○	○	○	○	○	○	○
外接电(线)缆 External cables	○	○	○	○	○	○	○	○	○	○
内部线路 Internal wiring	X	○	○	○	○	○	○	○	○	○
镜头支架 Lens holder	○	○	○	○	○	○	○	○	○	○
光学镜头 Optical lenses	○	○	○	○	○	○	○	○	○	○
紧固件,螺旋,垫圈,螺帽 Fasteners	X	○	○	○	○	○	○	○	○	○
激光发生器 Laser	○	○	○	○	○	○	○	○	○	○
电源供应器 Power Supply Unit	X	○	○	○	○	○	○	○	○	○
风扇 Fan	X	○	○	○	○	○	○	○	○	○
液晶显示面板 LCD panel	X	○	○	○	○	○	○	○	○	○

部件名称 Component name	有害物质 Hazardous Substances or Elements									
	铅 (Pb)	汞 (Hg)	镉 (Cd)	六价铬 (Cr ⁶⁺)	多溴联苯 (PBB)	多溴二苯醚 (PBDE)	邻苯二甲酸二正丁酯 (DBP)	邻苯二甲酸二异丁酯 (DIBP)	邻苯二甲酸丁基苄酯 (BBP)	邻苯二甲酸二(2-乙基)己酯 (DEHP)
附電池遙控器 Remote control	X	O	O	O	O	O	O	O	O	O
注1: O: 表示该有害物质在该部件所有均质材料中的含量均不超出电器电子产品有害物质限制使用国家标准要求。 X: 表示该有害物质至少在该部件的某一均质材料中含量超出电器电子产品有害物质限制使用国家标准要求。 注2: 以上未列出的部件, 表明其有害物质含量均不超出电器电子产品有害物质限制使用国家标准要求。										



D.9 Product compliance Taiwan

EMC notices Taiwan

BSMI Taiwan Class A statement

警告使用者: 此為甲類資訊技術設備, 於居住環境中使用, 可能會造成射頻擾動, 在此情況下, 使用者會被要求採取某些適當的對策。

BSMI Reporting Obligor Information / 報驗義務人資訊

製造商 (報驗廠商): 巴可股份有限公司/新北市板橋區新站路16號33樓。

- 一、 商品在國內產製時, 為商品之產製者或輸出者。
但商品委託他人產製, 並以在國內有住所或營業所之委託者名義, 於國內銷售或輸出時, 為委託者。
- 二、 商品在國外產製時, 為商品之輸入者。
但商品委託他人輸入, 並以在國內有住所或營業所之委託者名義, 於國內銷售時, 為委託者。
- 三、 商品之產製者、輸出入者、委託產製或委託輸出入者不明或無法追查時, 為銷售者。
前項所稱產製者, 包括具有下列情形之一者:
 - 一、 組裝者: 商品由個別零組件以組裝銷售。
 - 二、 修改者: 符合檢驗規定之商品於進入市場前, 為銷售目的而修改。

限用物質含有情況標示聲明書 (Declaration of the Presence Condition of the Restricted Substances Marking)

設備名稱： 投影機, 型號 (型式) : I600-4K8, I600-4K10, I600-4K15 Equipment name: Projector, Type designation: I600-4K8, I600-4K10, I600-4K15						
	限用物質及其化學符號 Restricted substances and its chemical symbols					
單元 Unit	鉛 Lead (Pb)	汞 Mercury (Hg)	鎘 Cadmium (Cd)	六價鉻 Hexavalent chromium (Cr6+)	多溴聯苯 Polybrominated biphenyls (PBB)	多溴二苯醚 Polybrominated diphenyl ethers (PBDE)
印製電路板配件 Printed Circuit Assemblies	—	○	○	○	○	○
外接電 (線) 纜 External cables	○	○	○	○	○	○
內部線路 Internal wiring	—	○	○	○	○	○
光學鏡頭 Optical lenses	○	○	○	○	○	○
鏡頭支架 Lens holder	○	○	○	○	○	○
螺帽, 螺釘 (栓), 螺旋 (釘), 墊圈, 緊固件 Nuts, bolts, screws, washers, fasteners	—	○	○	○	○	○
激光發生器 Laser	○	○	○	○	○	○
電源供應器 Power Supply Unit	—	○	○	○	○	○
風扇 Fan	—	○	○	○	○	○
液晶顯示面板 LCD panel	—	○	○	○	○	○
遙控器 Remote Control	—	○	○	○	○	○
<p>備考1. “超出0.1 wt %” 及 “超出0.01 wt %” 係指限用物質之百分比含量超出百分比含量基準值。 Note 1: “Exceeding 0.1 wt %” and “exceeding 0.01 wt %” indicate that the percentage content of the restricted substance exceeds the reference percentage value of presence condition.</p> <p>備考2. “○” 係指該項限用物質之百分比含量未超出百分比含量基準值。 Note 2: “○” indicates that the percentage content of the restricted substance does not exceed the percentage of reference value of presence.</p> <p>備考3. “—” 係指該項限用物質為排除項目。 Note 3: The “—” indicates that the restricted substance corresponds to the exemption.</p>						

D.10 Trademark notice

HDMI™

The terms HDMI, HDMI High-Definition Multimedia Interface, HDMI trade dress and the HDMI Logos are trademarks or registered trademarks of HDMI Licensing Administrator, Inc.

DisplayPort™

DisplayPort™, the DisplayPort™ logo and DisplayPortHDR™ logo are trademarks owned by the Video Electronics Standards Association (VESA®) in the United States and other countries.

USB Type-C™

USB Type-C and USB-C are a registered trademarks of USB Implementers Forum

HDBaseT™

HDBaseT™ and the HDBaseT Alliance logo are trademarks of the HDBaseT Alliance.

PJLink™

The PJLink™ is a registered trademark of Japan Business Machine and Information System Industries Association.

DLP™

DLP® and the DLP logo are registered trademarks of Texas Instruments.



All other trademarks and registered trademarks are trademarks or registered trademarks of their respective holders. In this manual, ™ and ® marks are not specified.

D.11 Product privacy statement

About

Learn more about Barco's Product Privacy Statement:

<https://www.barco.com/en/about/trust-center/product-privacy-statement>.

Which data is captured and why

Following data⁷ is captured for general secure operation of the product.

- IP addresses
- User ID information
- Date and time information
- Mobile network information
- Network configuration information
- Device identification information
- Device operational conditions
- Device environmental conditions
- Device performance metric
- Device configuration information
 - Resolution
 - Brightness
- Device input configuration
 - Active inputs

7. Only if applicable for the product type and model.

- Input resolution

Data retention mechanism

An administrator should modify or delete a user (upon user request, or when the user does not work for the company anymore), either via the Users feature, or via a factory reset executed as administrator.

Logs may contain user names and IP addresses and are subject to the retention policy, but cannot be deleted by the user. The user can send a request to dataprotection@barco.com.

Glossary

DMX

DMX-512 Lighting protocol over RS-485 interface. Carries information of 512 channels from a lighting controller to lighting devices. Standardized by USITT.

HD

Hazard Distance (HD) is the distance measured from the projection lens at which the intensity or the energy per surface unit becomes lower than the applicable exposure limit on the eye or on the skin. The light beam is considered (to be) unsafe for exposure if the distance from a person to the light source is less than the HD.

Index

A

Address
 Production 86
Airflow 24

B

Backlight 28
Basic RCU 31–32
 Batteries 32
Battery
 Disposal 87

C

Cleaning
 Exterior 62
 Lens 62
Communication 49–50
 DMX 52
Compliance 21, 85
 China 88
 EAC 88
 EU 86
 Taiwan 89
 Turkey 87
 UK 87
 US 87
Components
 Projector 24
Contact
 Address 86
Control 50

D

Dimensions 81
 Mounting holes 83
 Outer dimensions 82
Disposal 85–86

Battery 87
DMX chart 75
 Basic 76
 Extended 77
DMX Chart
 Input mapping 76
DMX input 52
DMX interface 52
DMX out 52
Download
 Product manual 21
Dust filter 55
 Vacuum cleaning 56
 Washing 57

E

Enclosed projection 18
EurAsian Conformity (EAC) 88
Exterior
 Cleaning 62

F

Fiber
 Input 53
 SFP 53
Function
 Button pressed indicator 38

G

General considerations 10

H

Hazard Distance 16, 18
 Modifying optics 20
 Multi-projector 20
 Projector stacks 20
Hazardous Chemicals 15

HDBaseT 51
High Brightness precautions 16

I

Importer 86
Info tri 21
Input 49, 51
 Fiber 53
 Quad Combo Mk III 51
 Quad DP 1.2 53
 SFP 53
 Small Form-factor Pluggable 53

L

LCD 29
LED behavior
 Quad DP 1.2 53
 SFP 53
Lens
 Cleaning 62
Link speed 44, 47
Local keypad 27–28
 Functions 28

M

Maintenance 59
Maintenance program
 Every month 60
mini-jack
 RCU 39

N

Notice
 Optical radiation 10
Notice on safety 10

O

Orientation
 Projector 24
OSD 29

P

Power
 Modes 44
Power mode
 Transition 46
Power off 43
Power Off 45
Power on 43
Power On 44
Privacy 91
Projector
 Components 24
 Orientation 24

Pulse Prospector
 Connecting 26
 Requirements 26
Pulse RCU 35
 battery 36
 Functionality overview 36
 on/off button 37
 Projector OSD on/off 39
 protection sleeve 40
 RGB button 38
 RGB filter 38
 Stealth Mode 39

Q

Quad Combo Mk III 51
Quad DP 1.2
 Introduction 53
 LED behavior 53

R

RCU
 mini-jack 39
 XLR 39
RCU Basic 31
RCU batteries 32
RCU functions 32
RCU Pulse 35
Rear projection 18
Regulatory 85
Remote control 31, 35
Replace
 Dust filter 56
RoHS
 China 88
 Taiwan 90

S

Safety 9
 Battery explosion 13
 Fire hazard 12
 Hazard Distance 16, 18
 Hazardous Chemicals 15
 Personal injury 12
 Projector damage 13
 Safety Data Sheet (SDS) 15
 Servicing 14
 Stacking 15
Safety Data Sheet (SDS) 15
Safety instructions 11
Safety labels 15
SFP
 Introduction 53
 LED behavior 53
SFP inputs
 Specifications 73
Software update 60
Software upgrade 60
Source
 Fiber 53

- SFP 53
- Small Form-factor Pluggable 53
- Specifications 63
 - DisplayPort 1.2 inputs 72
 - DisplayPort 1.4 inputs 71
 - HDBaseT inputs 71
 - HDMI inputs 70
 - I600-4K10 65
 - I600-4K15 67
 - I600-4K8 64
 - SDI inputs 69
 - SFP inputs 73
- Start 23
- Status 25
- Switching Off 45
- Switching On 44

T

- Touch panel 29
- Trademarks 91
- Turkey RoHS 87

U

- UK Compliance 21, 87
- User definition 11

W

- Wake-On-DMX 44
- Wake-On-LAN 44, 46–47
- WEEE 21, 86–87
- WOL 44, 47

X

- XLR
 - RCU 39



R5917789 /04 | 2024-12-23

www.barco.com